

Morse taper adapter according to DIN 228A

Application: For holding morse taper tools with tang according to DIN 228A.

Technical Design: Runout of outer taper to $D_1 \leq 0,008$ mm.

 **Balanced**
G 6,3 at 8.000^{min-1}

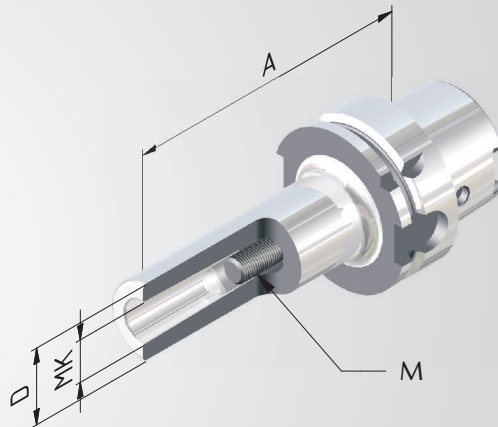

Order No.	HSK	MK	M	A	D
606314-01	63	1	M6	100	25
606314-02	63	2	M10	120	32
606314-03	63	3	M12	140	40
606314-04	63	4	M16	160	48

Morse taper adapter according to DIN 228B

Application: For holding morse taper tools with tang according to DIN 228B

Technical Design: Runout of outer taper to $D_1 \leq 0,008$ mm.

 **Balanced**
G 6,3 at 8.000^{min-1}

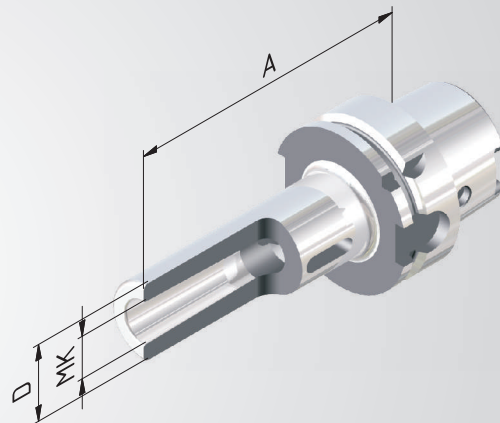

Order No.	HSK	MK	A	D
606313-01	63	1	100	25
606313-02	63	2	120	32
606313-03	63	3	140	40
606313-04	63	4	160	48