

Endmill holder Whistle Notch

- Application:** For clamping tools with cylindrical shank according to DIN 1835 E.
- Technical Design:** Runout of outer taper to $D_1 \leq 0,003$ mm. Tolerance of bore H4 (more accurate as DIN).
- Includes:** Clamping screw and set screw.
- Accessories:** See page 133.

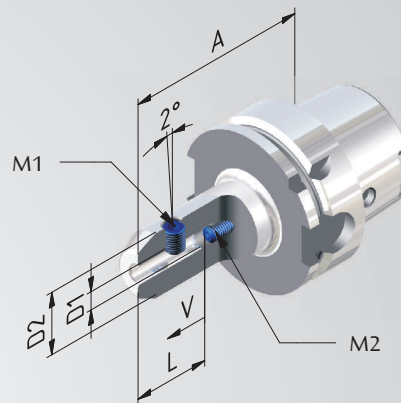

Order No.	HSK	D1	A	D2	L	M1	M2	V
SHORT								
606309-01	63	6	80	25	36,5	M6	M5	10
606309-02	63	8	80	28	36,5	M8	M6	10
606309-03	63	10	80	35	40,5	M10	M8	10
606309-04	63	12	90	42	45,5	M12	M10	10
606309-05	63	14	90	42	45,5	M12	M10	10
606309-06	63	16	100	48	48,5	M14	M12	10
606309-07	63	18	100	50	48,5	M14	M12	10
606309-08	63	20	100	52	50,5	M16	M16	10
606309-10	63	25	110	65	56,5	M18x2	M20	10
606309-11	63	32	110	72	60,5	M20x2	M20	10