

Shrink fit holder »Cool Tool« 4,5 °

- Application:** Particularly suitable for tools without internal coolant, and for machining at difficult positions with bad chip removal.
- Technical Design:** Two holes in the toolholder lead the coolant directly to the cutting edge. Coolant holes can be re-sealed with screws for the use of tools with internal coolant holes.
- Includes:** Set screw and 2 x M3 screws to plug the coolant holes if needed.
- Accessories:** See page 134.

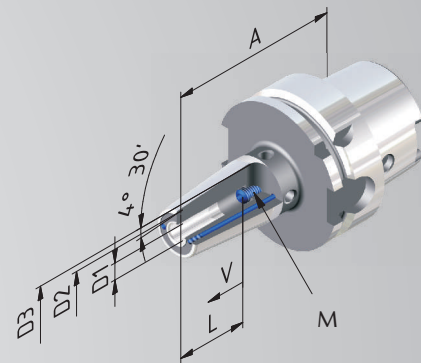

Fine balanced
G 2,5 at 25.000^{min}-1
or max. residual imbalance
≤ 1 gmm

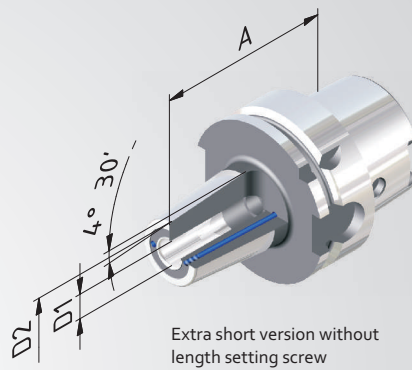

Order No.	HSK	D1	A	D2	D3	V	L	M
EXTRA SHORT								
6063219-03	63	10	70	26	33	-	42	-
6063219-04	63	12	70	26	33	-	48	-
6063219-06	63	16	75	29	37	-	51	-
6063219-08	63	20	75	35	43	-	53	-
6063219-09	63	25	85	45	50	-	59	-

Long versions see next page >>

Shrink fit holder »Cool Tool« 4,5 °



Fine balanced
G 2,5 at 25.000^{min}
or max. residual imbalance
≤ 1 gmm

Order No.	HSK	D1	A	D2	D3	V	L	M
SHORT								
606321-139*	63	3	80	12	17	-	-	-
606321-149*	63	4	80	12	17	-	-	-
606321-159*	63	5	80	12	17	-	-	-
606321-019	63	6	80	21	27	10	37	M5
606321-029	63	8	80	21	27	10	37	M6
606321-039	63	10	85	24	32	10	42	M8x1
606321-049	63	12	90	24	32	10	48	M10x1
606321-059	63	14	90	27	34	10	48	M10x1
606321-069	63	16	95	27	34	10	51	M12x1
606321-079	63	18	95	33	42	10	51	M12x1
606321-089	63	20	100	33	42	10	53	M16x1
606321-099	63	25	115	44	53	10	59	M16x1
= 120								
606321-319	63	6	120	21	27	10	37	M5
606321-329	63	8	120	21	27	10	37	M6
606321-339	63	10	120	24	32	10	42	M8x1
606321-349	63	12	120	24	32	10	48	M10x1
606321-359	63	14	120	27	34	10	48	M10x1
606321-369	63	16	120	27	34	10	51	M12x1
606321-379	63	18	120	33	42	10	51	M12x1
606321-389	63	20	120	33	42	10	53	M16x1
= 130								
606321-5139*	63	3	130	12	17	-	-	-
606321-5149*	63	4	130	12	17	-	-	-
606321-5159*	63	5	130	12	17	-	-	-
606321-519	63	6	130	21	27	10	37	M5
606321-529	63	8	130	21	27	10	37	M6
606321-539	63	10	130	24	32	10	42	M8x1
606321-549	63	12	130	24	32	10	48	M10x1
606321-559	63	14	130	27	34	10	48	M10x1
606321-569	63	16	130	27	34	10	51	M12x1
606321-579	63	18	130	33	42	10	51	M12x1
606321-589	63	20	130	33	42	10	53	M16x1
606321-599	63	25	130	44	53	10	59	M16x1
606321-609	63	32	130	44	53	10	63	M16x1

* Cool tool holes can not be plugged.