

Shrink fit holder 3°

Application: For clamping tools with cylindrical shank of solid carbide or HSS, tol. h6.

Technical Design: Made of special heat resistant steel. Suitable for inductive shrinking unit. Runout of outer taper to $D_1 \leq 0,003$ mm.



Fine balanced
 $G_{2,5}$ at 25.000min^{-1}
 or max. residual imbalance
 ≤ 1 gmm

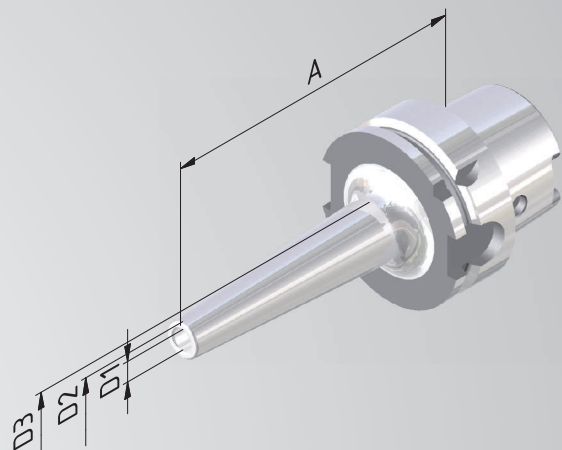
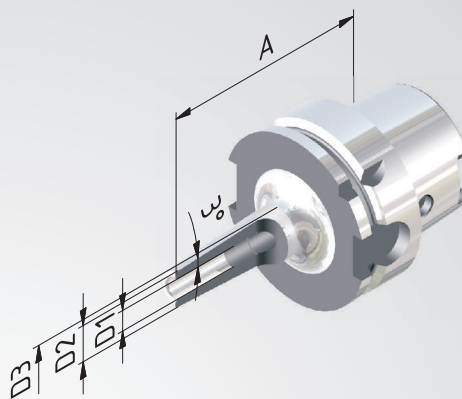

Order No.	HSK	D1	A	D2	D3
SHORT					
606351-13	63	3	80	9	14
606351-14	63	4	80	10	15
606351-15	63	5	80	11	16
606351-01	63	6	80	12	18
606351-02	63	8	80	14	20
606351-03	63	10	80	16	22
606351-04	63	12	80	18	24
= 120					
606351-313	63	3	120	9	18
606351-314	63	4	120	10	19
606351-315	63	5	120	11	20
606351-31	63	6	120	12	22
606351-32	63	8	120	14	24
606351-33	63	10	120	16	26
606351-34	63	12	120	18	28