

Shrink fit extensions without length adjustment screw

**Application:** For the extension of tool holders. Cylindrical shank can be clamped in end mill holder or collet chuck.

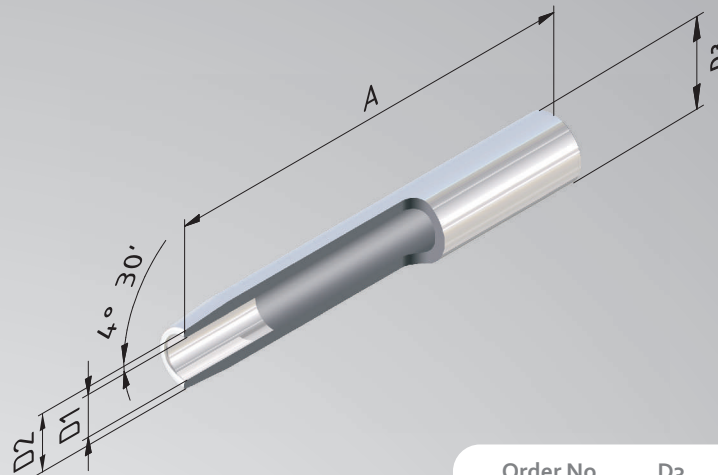

Order No.	D3	D1	D2	A
				= 160
2112-13	12	3	8	160
2112-14	12	4	8	160
2116-13	16	3	10	160
2116-14	16	4	10	160
2116-15	16	5	10	160
2116-01	16	6	10	160
2120-15	20	5	14	160
2120-01	20	6	14	160
2120-02	20	8	14	160
2125-02	25	8	19	160
2125-03	25	10	20	160
2125-04	25	12	20	160
2125-05	25	14	20	160
2125-06	25	16	22	160
2132-03	32	10	24	160
2132-04	32	12	24	160
2132-05	32	14	27	160
2132-06	32	16	27	160
2132-07	32	18	27	160
2132-08	32	20	27	160

Shrink fit extensions without length adjustment screw

**Application:** For the extension of tool holders. Cylindrical shank can be clamped in end mill holder or collet chuck.

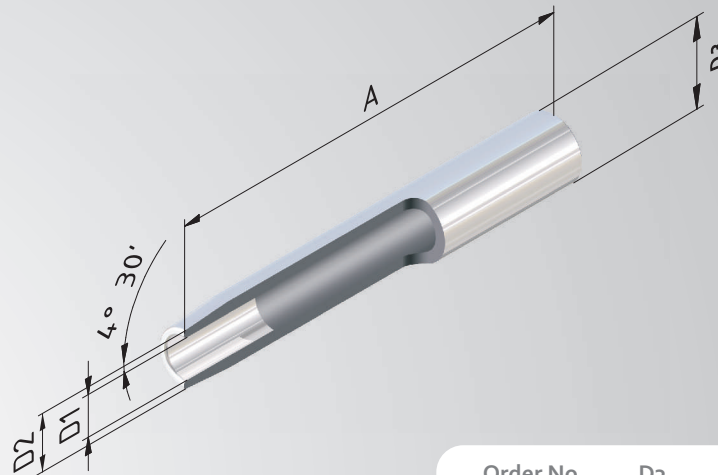

Order No.	D3	D1	D2	A
				= 300
2120-61	20	6	14	300
2120-62	20	8	14	300
2125-62	25	8	19	300
2125-63	25	10	20	300
2125-64	25	12	20	300
2125-65	25	14	20	300
2125-66	25	16	22	300
2132-63	32	10	24	300
2132-64	32	12	24	300
2132-65	32	14	27	300
2132-66	32	16	27	300
2132-68	32	20	27	300

Shrink fit extensions »cool tool« without length adjustment screw

**Application:** For the extension of tool holders. Cylindrical shank can be clamped in end mill holder or collet chuck.

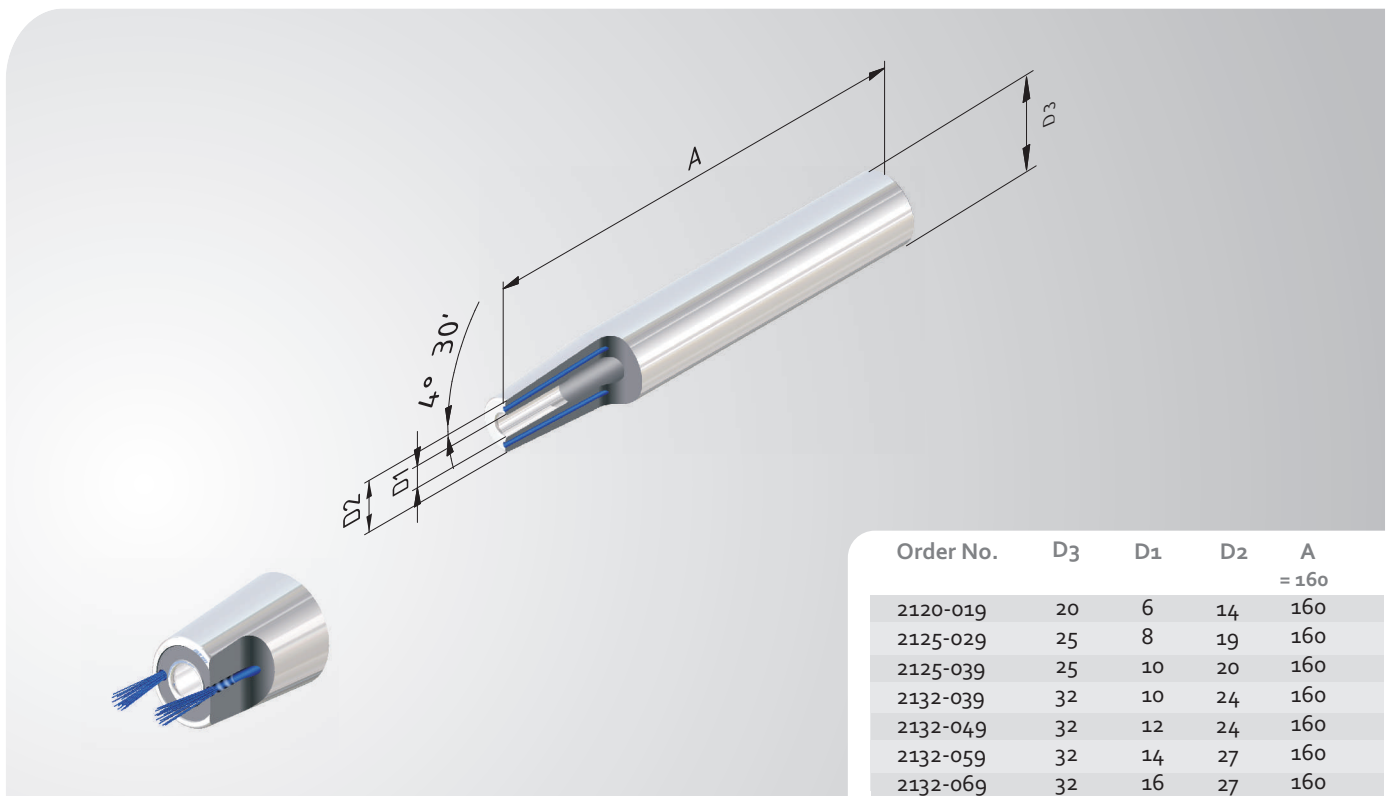

Shrink fit extensions with length adjustment screw

- Application:** For the extension of tool holders. Cylindrical shank can be clamped in end mill holder or collet chuck.
- Includes:** Clamping screw.
- Accessories:** See page 133.

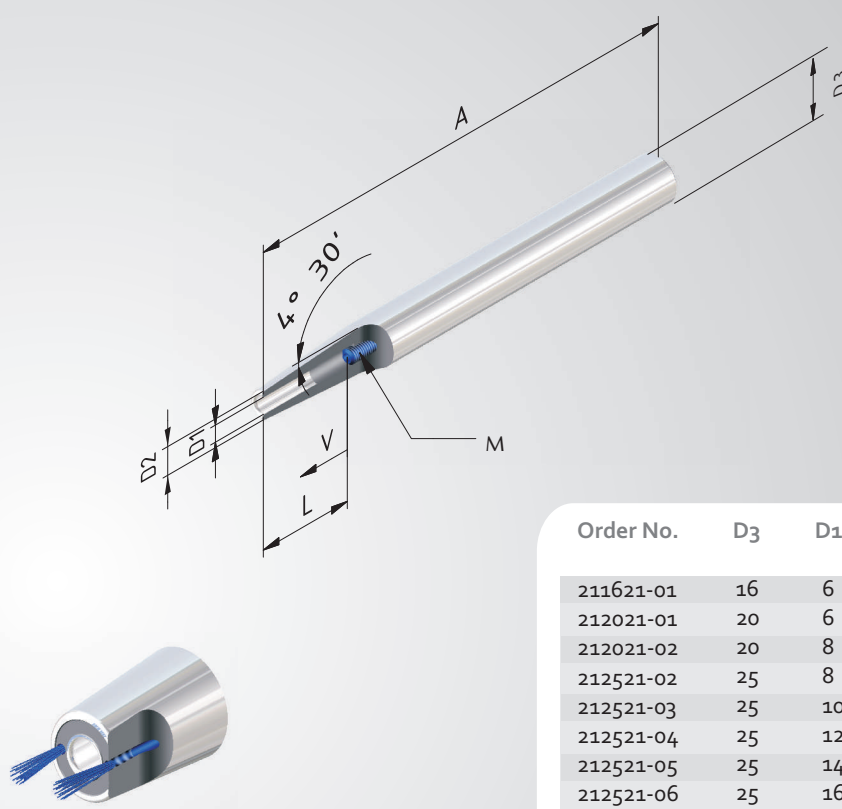

Order No.	D <sub>3</sub>	D <sub>1</sub>	D <sub>2</sub>	A = 160	V	L	M
211621-01	16	6	10	160	10	37	M5
212021-01	20	6	14	160	10	37	M5
212021-02	20	8	14	160	10	37	M6
212521-02	25	8	19	160	10	37	M6
212521-03	25	10	20	160	10	42	M8x1
212521-04	25	12	20	160	10	48	M10x1
212521-05	25	14	20	160	10	48	M10x1
212521-06	25	16	22	160	10	51	M12x1
213221-03	32	10	24	160	10	42	M8x1
213221-04	32	12	24	160	10	48	M10x1
213221-05	32	14	27	160	10	48	M10x1
213221-06	32	16	27	160	10	51	M12x1
213221-07	32	18	27	160	10	51	M12x1
213221-08	32	20	27	160	10	53	M16x1