

Sealed ER-collets with jet nozzels »Cool Tool« – repeatable accuracy of collet 2 μ

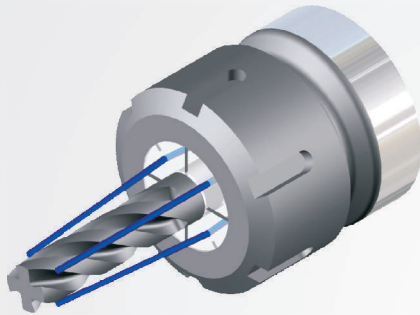
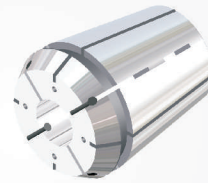

fig.: Collet with jet nozzels »Cool Tool« for tool holders without internal cooling.



- Highest runout accuracy combined with effective cooling and chip removal.
- Applicable up to 120 bar.
- Only shanks with nominal size can be used, tolerance h8.
- Shanks with lateral clamping flat can only be used limited. Which means the clamping flat has to be behind the sealing plug, otherwise the coolant can leak along the shank.

Order No.	ER	Diameter
129-3xx	25	4/6/8/10/12/14
129-4xx	32	4/6/8/10/12 14/16/18

Please complete the item number with the respective diameter of the collet, i.e. ER 25 with \varnothing 8 = 129-308.

Sealed ER-collets – repeatable accuracy of collet 5 μ

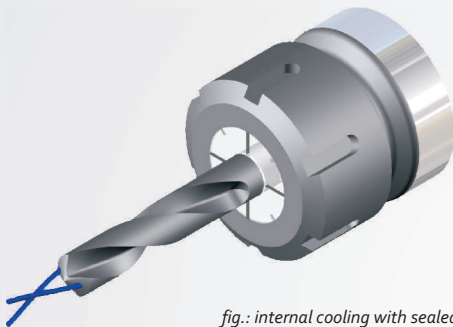
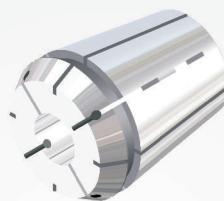

fig.: internal cooling with sealed collet.



- For tools with internal coolant up to 120 bar!
- Only shanks with standard dimensions can be used, tolerance h8.
- Shanks with lateral clamping flat can only be used limited, which means the clamping flat has to be behind the sealing plug, otherwise the coolant can leak along the shank.

Order No.	ER	Diameter
128-1xx	16	3/4/6/8/10 5/7/9
128-2xx	20	3/4/6/8 10/12 5/7/9/11
128-3xx	25	4/6/8/10/12 14/16 3/5/7/9/11 13/15
128-4xx	32	4/6/8/10/12 14/16/18/20 3/5/7/9/11 13/15/17/19
128-5xx	40	6/8/10/12/14 16/18/20/25

Please complete the item number with the respective diameter of the collet, i.e. ER 25 with \varnothing 10 = 128-310.