

Shrink fit holder 4,5°

Application: For clamping tools with cylindrical shank of solid carbide or HSS, tol. h6.

Technical Design: Made of special heat resistant steel. Suitable for inductive shrinking unit. With four additional threads for supplementary fine balancing. Runout of outer taper to $D_1 \leq 0,003$ mm.

Includes: Set screw.

Accessories: See page 133.



Fine balanced
 $G 2,5$ at 25.000^{rpm}
or max. residual imbalance
 ≤ 1 gmm

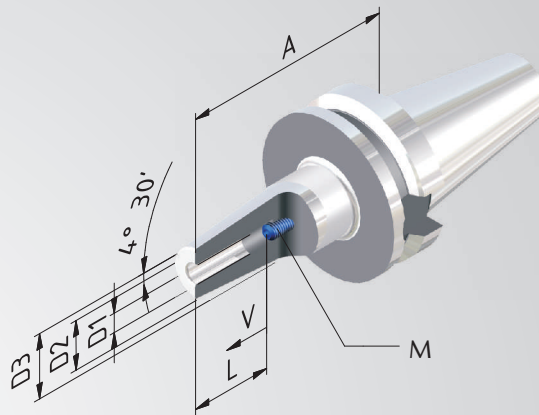

Order No.	BT	D1	A	D2	D3	V	L	M
SHORT								
753021-13	30	3	80	12	17	-	-	-
753021-14	30	4	80	12	17	-	-	-
753021-15	30	5	80	12	17	-	-	-
753021-01	30	6	80	21	27	10	37	M5
753021-02	30	8	80	21	27	10	37	M6
753021-03	30	10	80	24	32	10	42	M8x1
753021-04	30	12	80	24	32	10	48	M10x1
753021-05	30	14	80	27	34	10	48	M10x1
753021-06	30	16	80	27	34	10	51	M12x1
753021-07	30	18	90	33	42	10	51	M12x1
753021-08	30	20	90	33	42	10	53	M16x1