

Short drill chuck

Application: For clamping tools with cylindrical shank. Also suitable for tools with internal coolant.

Technical Design: Wrench.



Balanced
G 6,3 at 8.000^{mm}⁻¹

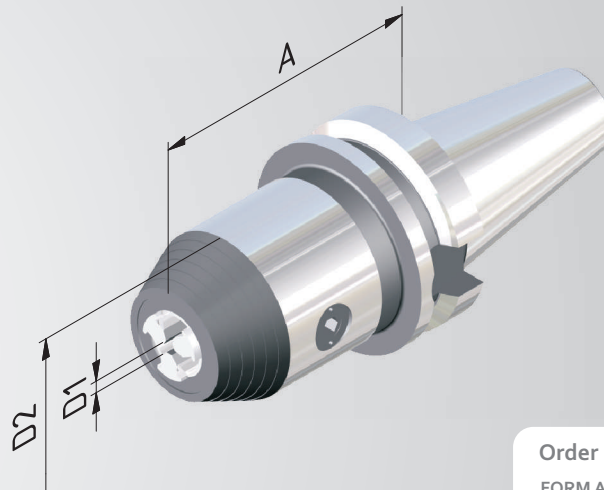

Order No.	BT	Clamping range	A	D2
FORM A without internal coolant				
754095-01	40	1-13	89	45
754095-02	40	1-16	95	56
FORM AD for tools with internal coolant				
754095-31	40	1-13	89	45
754095-32	40	1-16	95	56