

Shell mill holder »Cool Tool«

Application: For adapting shell mills with coolant through to the cutting edges.

Technical Design: With extended flange. Runout of outer taper to $D_1 \leq 0,006$ mm.

Includes: Clamping screw and drive keys.

Accessories and Spareparts: See page 134.



Fine balanced
G 2,5 at 25.000^{min}
or max. residual imbalance
 ≤ 1 gmm

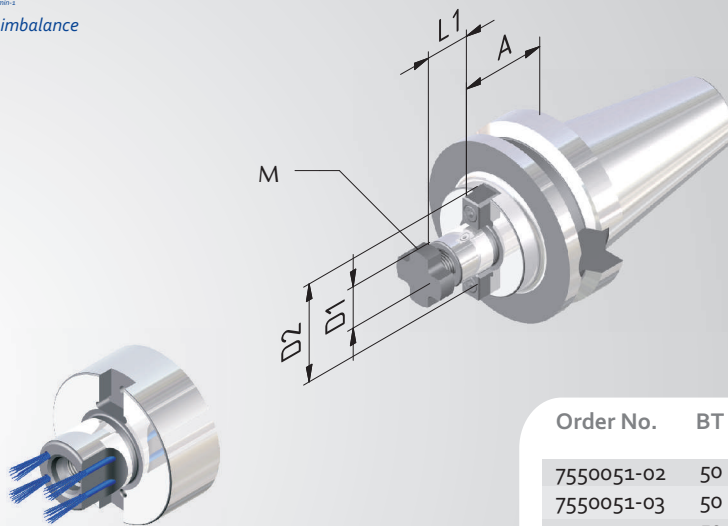

Order No.	BT	D1	A	D2	l ₁	M
			= 55			
7550051-02	50	22	55	48	19	M8
7550051-03	50	27	55	60	21	M10
7550051-04	50	32	55	78	24	M12
7550051-05	50	40	55	89	27	M16
			= 100			
7550051-32	50	22	100	48	19	M8
7550051-33	50	27	100	60	21	M10
7550051-34	50	32	100	78	24	M12