

Endmill holder Whistle Notch

- Application:** For clamping tools with cylindrical shank according to DIN 1835 E.
- Technical Design:** Runout of outer taper to $D_1 \leq 0,003$ mm. Tolerance of bore H4 (more accurate as DIN).
- Includes:** Clamping screw and set screw.
- Accessories:** See page 133.

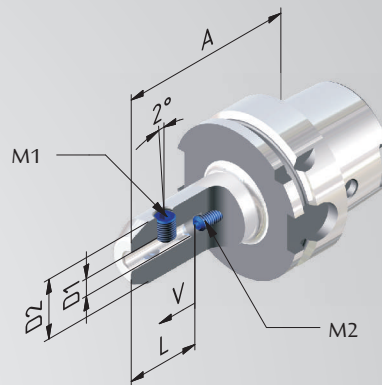

Order No.	HSK	D1	A	D2	L	M1	M2
			SHORT				
610009-01	100	6	90	25	36,5	M6	M5
610009-02	100	8	90	28	36,5	M8	M6
610009-03	100	10	90	35	40,5	M10	M8
610009-04	100	12	100	42	45,5	M12	M10
610009-05	100	14	100	42	45,5	M12	M10
610009-06	100	16	100	48	48,5	M14	M12
610009-07	100	18	100	50	48,5	M14	M12
610009-08	100	20	110	52	50,5	M16	M16
610009-10	100	25	120	65	56,5	M18x2	M20
610009-11	100	32	120	72	60,5	M20x2	M20