

### Morse taper adapter according to DIN 228A

**Application:** For holding morse taper tools with tang according to DIN 228A.

**Technical Design:** Runout of outer taper to  $D_1 \leq 0,008$  mm.



Balanced  
G 6,3 at 8.000<sup>min-1</sup>

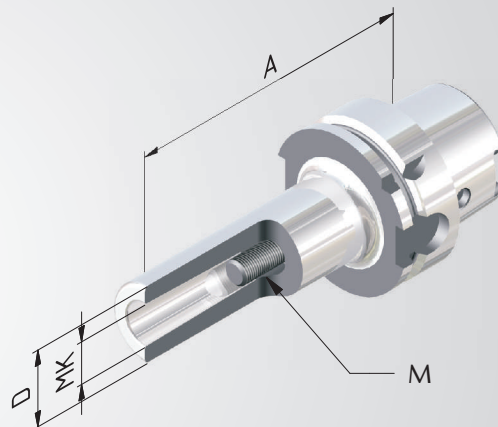

Order No.	HSK	MK	M	A
610014-02	100	2	M10	120
610014-03	100	3	M12	150
610014-04	100	4	M16	170

### Morse taper adapter according to DIN 228B

**Application:** For holding morse taper tools with tang according to DIN 228B.

**Technical Design:** Runout of outer taper to  $D_1 \leq 0,008$  mm.



Balanced  
G 6,3 at 8.000<sup>min-1</sup>

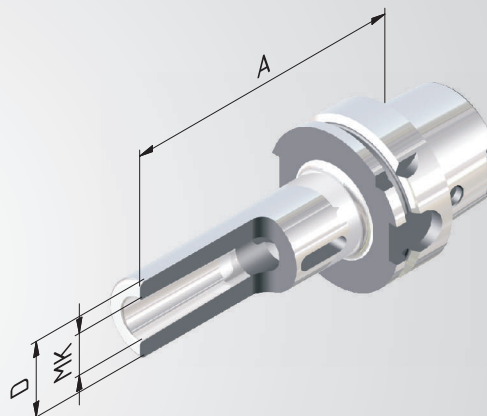

Order No.	HSK	MK	A	D
610013-01	100	1	110	25
610013-02	100	2	120	32
610013-03	100	3	150	40
610013-04	100	4	170	48