

Endmill holder Weldon

- Application:** For clamping tools with cylindrical shank according to DIN 1835 B.
- Technical Design:** Runout of outer taper to $D_1 \leq 0,003$ mm. Tolerance of bore H4 (more accurate as DIN).
- Includes:** Clamping screw.
- Accessories:** See page 132.

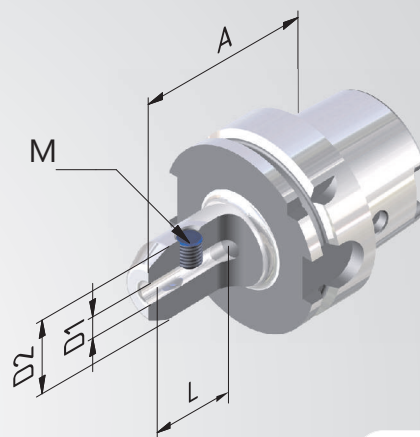

Fine balanced
 $G_{2,5}$ at 25.000^{rpm-1}
 or max. residual imbalance
 ≤ 1 gmm



Order No.	HSK	D1	A	D2	L	M
608004-01	80	6	80	25	35	M6
608004-02	80	8	80	28	35	M8
608004-03	80	10	80	35	41	M10
608004-04	80	12	80	42	48	M12
608004-06	80	16	100	48	51	M14
608004-08	80	20	100	52	53	M16
608004-09	80	25	100	65	60	M18x2
608004-10	80	32	110	72	64	M20x2