

Shrink fit holder 4,5°

- Application:** For clamping tools with cylindrical shank of solid carbide or HSS, tol. h6.
- Technical Design:** Made of special heat resistant steel. Suitable for inductive shrinking unit. With four additional threads for supplementary fine balancing. Runout of outer taper to $D_1 \leq 0,003$ mm.
- Includes:** Set screw.
- Accessories:** See page 133.

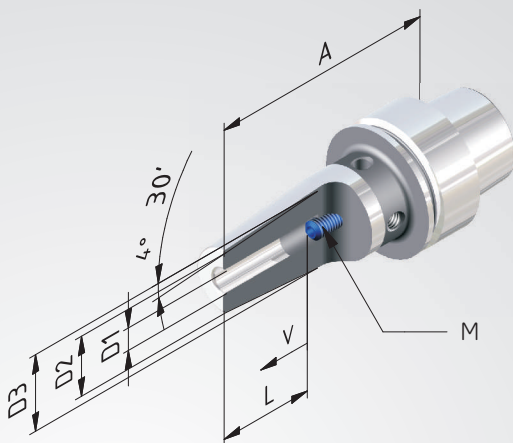

Fine balanced
 $G_{2,5}$ at $25.000^{mm/s}$
 or max. residual imbalance
 ≤ 1 gmm



Order No.	HSK	D1	A	D2	D3	V	L	M
		40 EXTRA SHORT						
404021-001	40	6	60	21	27	-	36	-
404021-002	40	8	60	21	27	-	36	-
404021-003	40	10	60	24	32	-	42	-
404021-004	40	12	60	24	32	-	47	-
404021-006	40	16	60	27	34	-	50	-
		SHORT						
404021-13	40	3	60	12	17	-	-	-
404021-14	40	4	60	12	17	-	-	-
404021-15	40	5	60	12	17	-	-	-
404021-01	40	6	80	21	27	10	37	M5
404021-02	40	8	80	21	27	10	37	M6
404021-03	40	10	80	24	32	10	42	M8x1
404021-04	40	12	90	24	32	10	48	M10x1
404021-05	40	14	90	27	34	10	48	M10x1
404021-06	40	16	90	27	34	10	51	M12x1

Order No.	HSK	D1	A	D2	D3	V	L	M
		50 SHORT						
405021-13	50	3	60	12	17	-	-	-
405021-14	50	4	60	12	17	-	-	-
405021-15	50	5	60	12	17	-	-	-
405021-01	50	6	80	21	27	10	37	M5
405021-02	50	8	80	21	27	10	37	M6
405021-03	50	10	85	24	32	10	42	M8x1
405021-04	50	12	90	24	32	10	48	M10x1
405021-05	50	14	90	27	34	10	48	M10x1
405021-06	50	16	95	27	34	10	51	M12x1