

Endmill holder Weldon

- Application:** For clamping tools with cylindrical shank according to DIN 1835 B.
- Technical Design:** Runout of outer taper to $D_1 \leq 0,003$ mm. Tolerance of bore H4 (more accurate as DIN).
- Includes:** Clamping screw.
- Accessories:** See page 132.

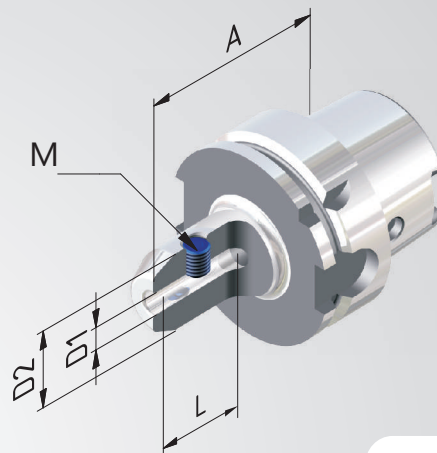

Fine balanced
 $G 2,5$ at 25.000^{rpm}
or max. residual imbalance
 ≤ 1 gmm



Order No.	HSK	D1	A	D2	L	M1
	40		SHORT			
604004-01	40	6	60	25	35	M6
604004-02	40	8	60	28	35	M8
604004-03	40	10	60	35	41	M10
604004-04	40	12	70	42	48	M12
604004-05	40	14	75	42	48	M12
604004-06	40	16	75	48	51	M14
	50		SHORT			
605004-01	50	6	65	25	35	M6
605004-02	50	8	65	28	35	M8
605004-03	50	10	65	35	41	M10
605004-04	50	12	80	42	48	M12
605004-06	50	16	80	48	51	M14
605004-08	50	20	80	52	53	M16