

Shrink fit holder

Application: For clamping tools with cylindrical shank of solid carbide or HSS, tol. h6.

Technical Design: Made of special heat resistant steel. Suitable for inductive shrinking unit. With four additional threads for supplementary fine balancing. Runout of outer taper to $D_1 \leq 0,003$ mm.

Includes: Set screw.

Accessories: See page 133.



Fine balanced
 $G_{2,5}$ at 25.000^{rpm}
 or max. residual imbalance
 ≤ 1 gmm

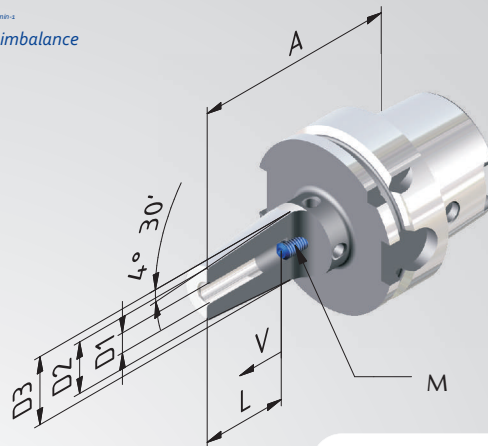

Order No.	HSK	D1	A	D2	D3	V	L	M
	40		SHORT					
604021-13	40	3	60	12	17	-	-	-
604021-14	40	4	60	12	17	-	-	-
604021-15	40	5	60	12	17	-	-	-
604021-01	40	6	80	21	27	10	37	M5
604021-02	40	8	80	21	27	10	37	M6
604021-03	40	10	80	24	32	10	42	M8x1
604021-04	40	12	90	24	32	10	48	M10x1
604021-05	40	14	90	27	34	10	48	M10x1
604021-06	40	16	90	27	34	10	51	M12x1
	50		SHORT					
605021-13	50	3	60	12	17	-	-	-
605021-14	50	4	60	12	17	-	-	-
605021-15	50	5	60	12	17	-	-	-
605021-01	50	6	80	21	27	10	37	M5
605021-02	50	8	80	21	27	10	37	M6
605021-03	50	10	85	24	32	10	42	M8x1
605021-04	50	12	90	24	32	10	48	M10x1
605021-05	50	14	90	27	34	10	48	M10x1
605021-06	50	16	95	27	34	10	51	M12x1
605021-07	50	18	95	33	42	10	51	M12x1
605021-08	50	20	100	33	42	10	53	M16x1