

Shell mill holder

- Application:** For adapting shell mills with transverse slot.
- Technical Design:** With extended flange. Runout of outer taper to $D_1 \leq 0,006$ mm.
- Includes:** Clamping screw and drive keys.
- Accessories:** See page 134.

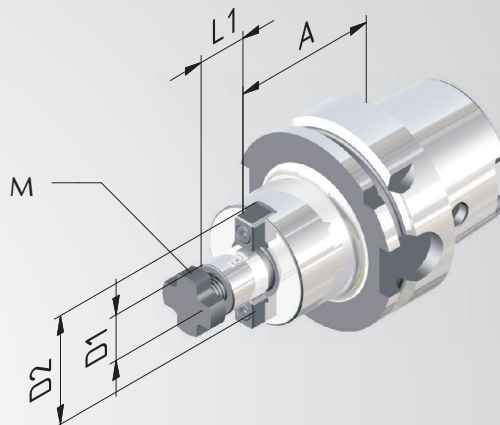

Fine balanced
 $G 2,5$ at 25.000^{rpm-1}
or max. residual imbalance
 ≤ 1 gmm



Order No.	HSK	D1	A	D2	l1	M
	40	SHORT				
604005-01	40	16	50	38	17	M8
604005-02	40	22	60	48	19	M10
	50					
605005-01	50	16	50	38	17	M8
605005-02	50	22	60	48	19	M10
605005-03	50	27	60	60	21	M12