

EROWA ITS chuck

Simple, practical, good

EROWA's ITS chuck operates on a principle that is as simple as it is ingenious. It holds both tools and workpieces with equal precision and with a high degree of repeatability. Its applications are so numerous that it forms the basis for a well thought-out modular tooling system.

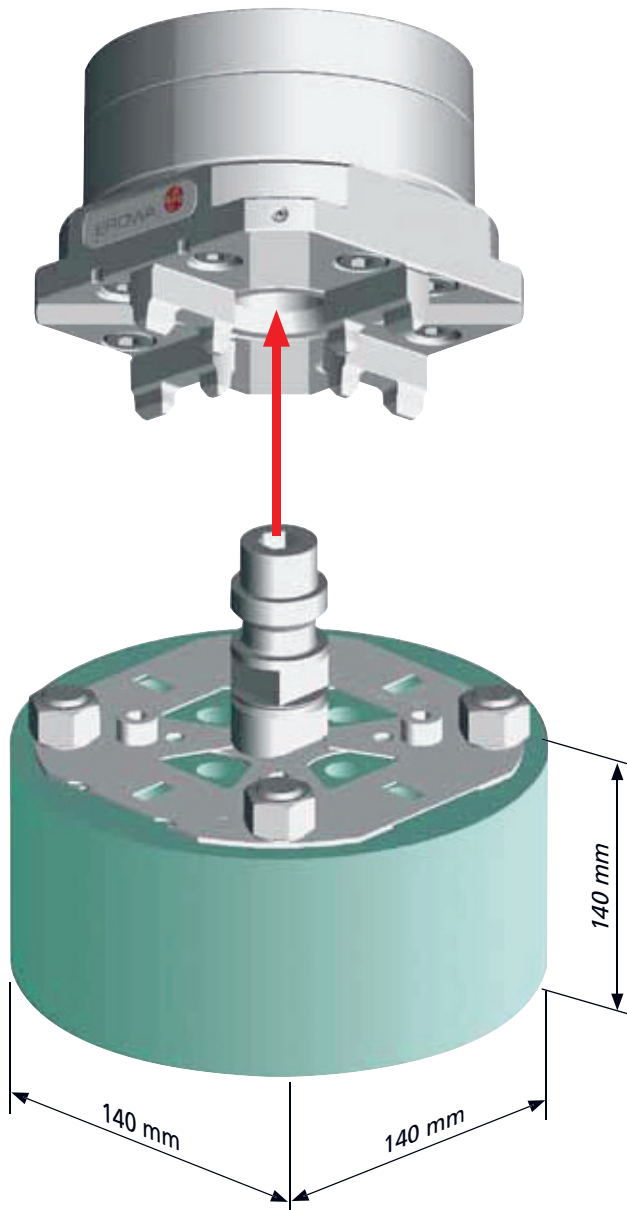

- Tens of thousands of ITS chucks are in daily operation worldwide - with their guaranteed 2- μ m accuracy and with a reliability they have earned for themselves in practical working application.
- Integrated on milling, grinding and drilling machines, on EDM sinking and WEDM centers or on measuring and presetting stations, ITS helps us week after week to achieve a profitable use of production time.

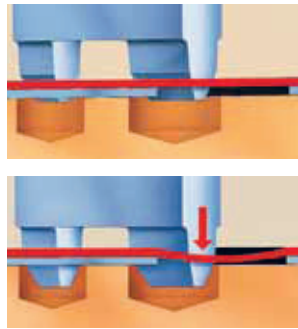

The two pictures illustrate the ITS patent. After a rough pre-centering process, the reference position is only reached when the centering plate is flexed. Together with the contact points, this flexing action creates the stability of the frictional connection. This is how positioning accuracy is created between the flexible centering plate and the rigid centering prisms.

ITS The  riginal.

Nothing is copied as fast as a pioneering invention. But then a copy always lags behind the times. It won't be different with the next innovative idea. We will ensure that you continue to do well if you invest your money in originals. In originals by EROWA.

Applications



Handling

Manual / Loading facility / Robot

Function

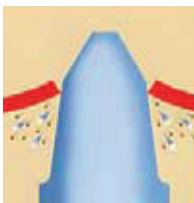
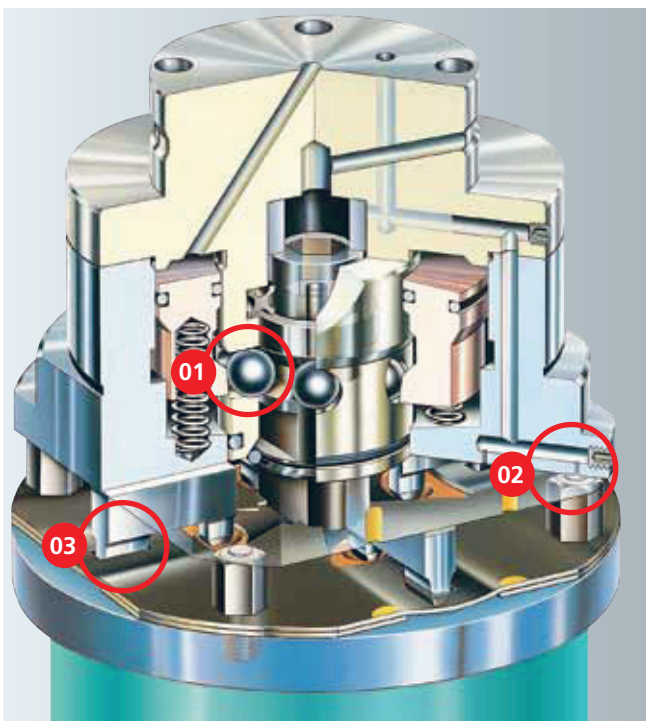

03 | Precision

The second important effect: the flexing plate wipes off any dirt. Centering plate and prism only touch on one line. A small contact area also reduces the possibility of interference by chips and dirt particles.

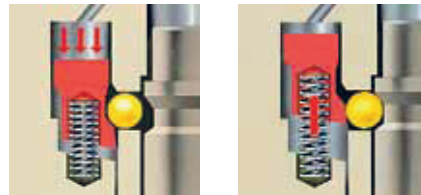

01 | Ball lock

The reliable clamping mechanism with the self-locking ball lock generates a clamping power of up to 7,000 N (NSF) and does not unlock even if the pressure fails.

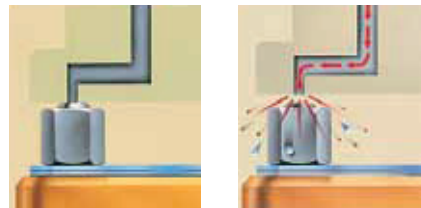

02 | Cleaning

Experience shows that precision and dirt do not go hand in hand. This is why the contact points of the support feet are cleaned with compressed air at the very moment of clamping. This also functions when the chuck is submerged in liquid.

Technical data - ITS chuck

	ITS chuck, pneumatic
System sizes	50 and 100
Repeatability	0.002 mm
Indexing	4 x 90°
Clamping power	2,500 N - 7,000 N
Recommended workpiece sizes	up to 140 x 140 x 140 mm
Generated by	springs (+ 6 bar NSF chucks)
Opening	compressed air min. 6 bar
Operation	control unit or air jet

EROWA ITS chuck in action

A suitable version for each job

The applications of ITS chucks are as numerous as the jobs to be done in precision mechanics and in tool and mold manufacturing. This is why we offer such a diverse variety of chucks.

SAVE TIME

Machine changes and in-process-control without loss of time thanks to fixed reference position.

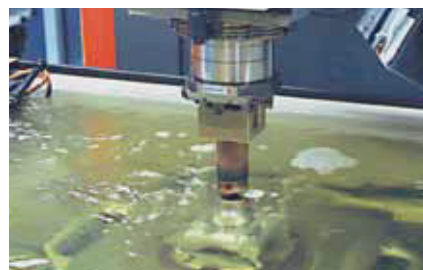
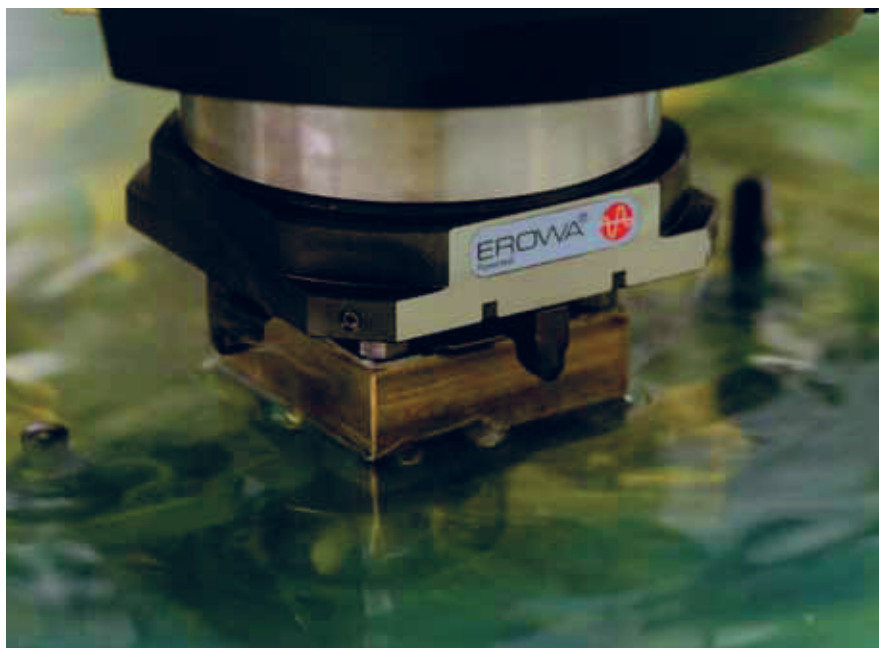

Precision and reliability in the tank and on the quill of the EDM machine.



ITS chucks can be used on all machines.



Ideally suitable for milling, drilling, grinding, turning . . .

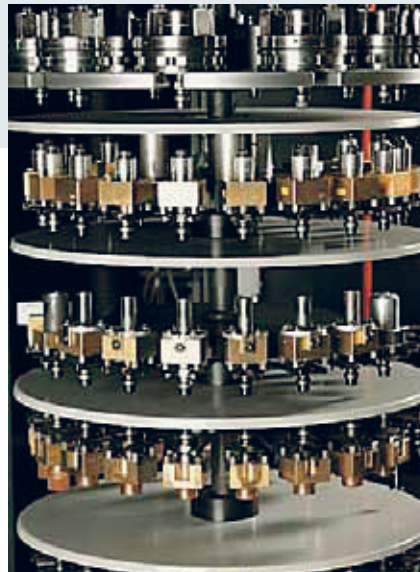

Exploit marginal and night hours by loading EDM machines automatically: ITS provides you with the necessary prerequisites.



ITS chucks: Perfectly suited for integration in special fixtures.

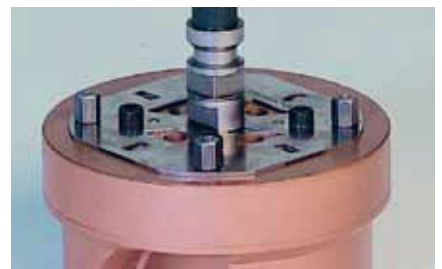

The centering plate is fitted directly on to the electrode or the workpiece...
...which is then transferred to the ITS chuck at once!



Checking outside the machine: quick, simple, precise.



Loading machines with preset parts will increase your capacity.



High degree of safety. The sealing plate of the EROWA ITS 50 holder C and the sealing ring constitute a form-fit seal. This provides the chuck with maximum protection against contamination.





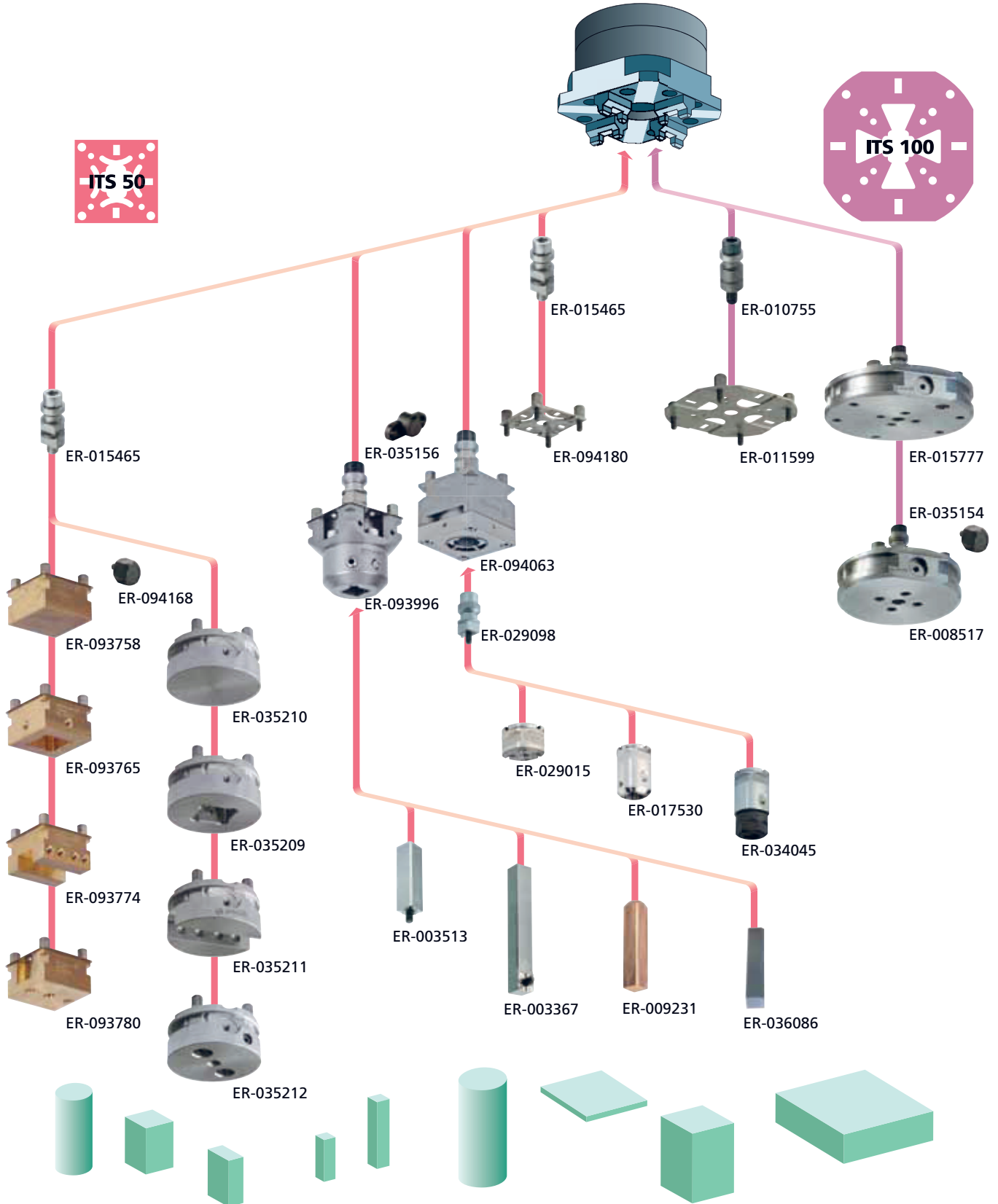











Integrated tooling system

The components





To make it easier for you to find your way about the fields of application for EROWA products, we use the following symbols in all our documents:

- | | |
|---|---|
|  | 1. Manual operation |
|  | 2. Operate with compressed air jet |
|  | 3. Operate with manual valve |
|  | 4. Operate with manual control unit |
|  | 5. Operate with electro-pneumatic control unit |
|  | 6. With central flushing clearance |
|  | 7. Suited for submerged operation |
|  | 8. Corrosion-resistant material |
|  | 9. Suited for automatic operation |
|  | 10. Handling with EROWA Robot gripper S |
|  | 11. Handling with EROWA Robot gripper Combi |
|  | 12. Handling with EROWA Robot gripper C |
|  | 13. Handling with EROWA Robot gripper 72 |
|  | 14. Handling with EROWA Robot gripper 115 |
|  | 15. Handling with EROWA Robot gripper 148 |
|  | 16. Handling with EROWA Robot gripper RN PC 210 |
|  | 17. Handling with EROWA Robot gripper RCS |

EROWA ITS TOOLING SYSTEM

EROWA ITS chucks

ITS chucks - a survey	156
ITS chuck, pneumatic, quill	158
ITS chuck, pneumatic, table, able to automate	160
ITS chuck, pneumatic, table, manual	161
ITS chuck, pneumatic, table, able to automate, INOX	163
ITS chuck, manual, quill	165
ITS chuck, manual, table, INOX	166
ITS screw chuck, manual	167
ITS chuck accessories	168
EROWA ITS system carriers	172
ITS centering plates	174
ITS standard electrode holders	175
Holder \varnothing 72	177
ITS precision pallets	180
EROWA ITS chucking spigots	186
EROWA ITS square electrode system and system plus	188
Square electrode clamping system 15/System Plus	190
Square electrode clamping system 25/System Plus	195
EROWA ITS special electrode holders	200
EROWA ITS measuring and controlling components	206
EROWA ITS element set	210
EROWA ITS auxiliary equipment	240
Chuck operation	240
Toolroom accessories	242
Spare parts	245



For chip-removing processes



For EDM sinking



For WEDM

EROWA ITS chucks

Pneumatically activated

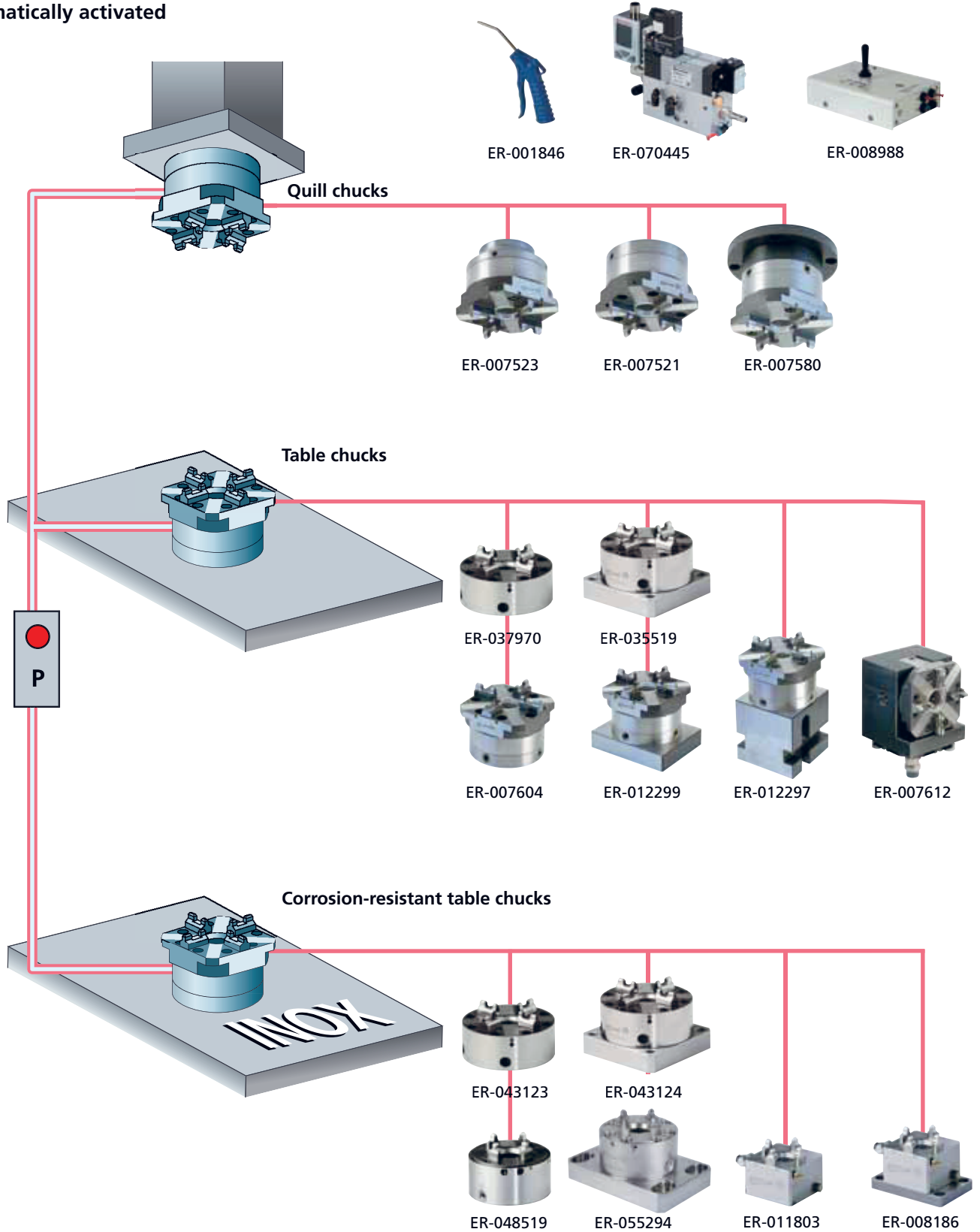

Mechanically activated

Quill chucks

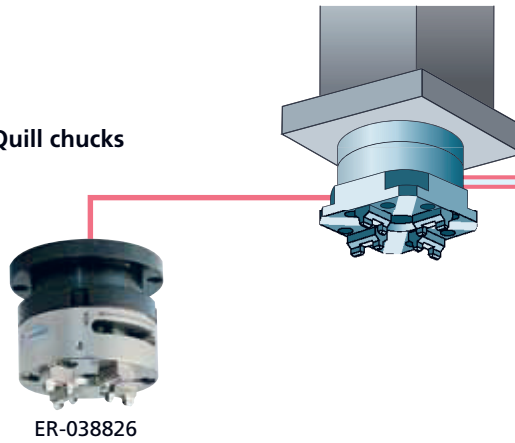

ITS - THE ORIGINAL

Tens of thousands in successful operation and patented worldwide since 1984.

Corrosion-resistant table chucks

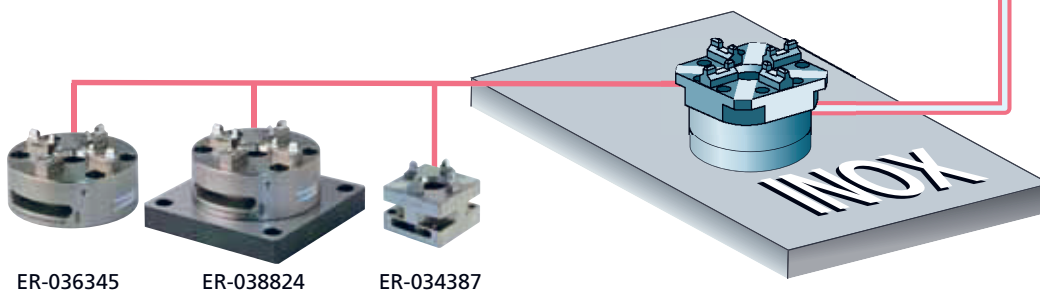

ITS

EROWA ITS chucks pneumatic, quill

Technical data	Chuck	Chuck «NSF» (with reclamping)
Repeatability	0.002 mm	0.002 mm
Indexing	4 x 90°	4 x 90°
Generated by	springs	springs
Opening	min. 6 bar	min. 6 bar
Reclamp		min. 6 bar

ER-007521 Rapid-action chuck automatic



Version Standard type. Clamping power up to 2500 N.
 Connections On back.
 Application EDM sinking machines with automatic electrode change, machine tools with automatic loading, production lines.

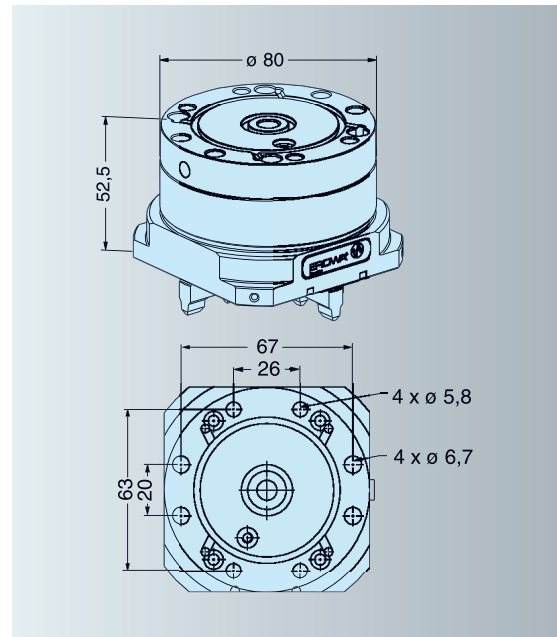

ER-007523 Rapid-action chuck automatic with shoulder for flushing



Version Shoulder for flushing connection. Clamping power up to 2500 N.
 Connections On back.
 Application EDM sinking machines with automatic electrode change.

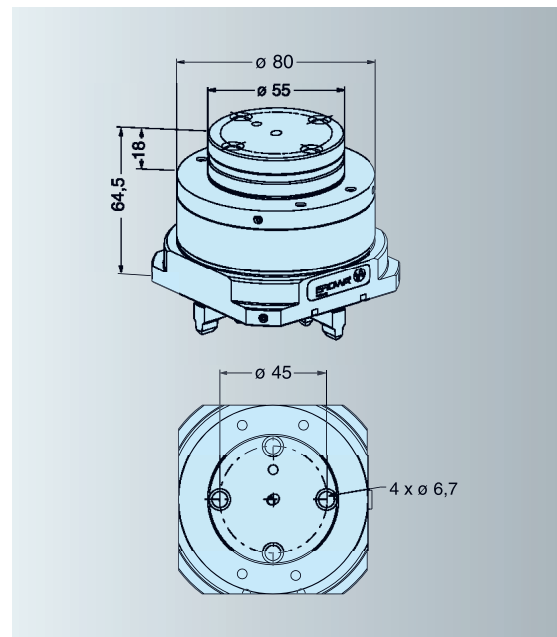

ER-007580 Manual rapid-action chuck

- Version With flange \varnothing 110 mm. Clamping power up to 2500 N.
- Connections Hose coupling fitting on side.
- Application Retrofitting on EDM sinking machines.

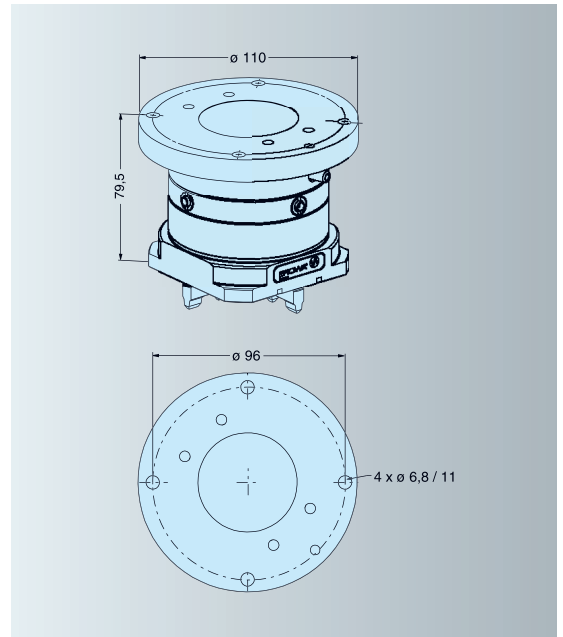

EROWA ITS chucks

pneumatic, table, able to automate

ER-037970 ITS chuck 100 P without base plate



Version	Steel, hardened.
Clamping power	6000 N.
Connections	At the rear, with two lines.
Operation	With control unit.
Application	For receiving pallets $\varnothing 115 / \varnothing 148$, electrode holders, pallets PM56, PM60 and PM85 Precise.

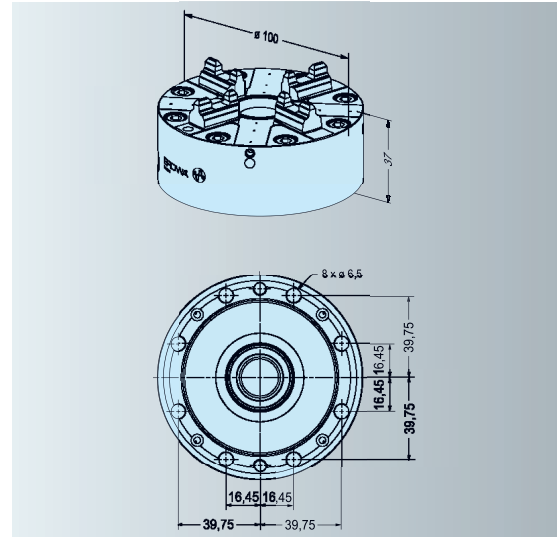

ER-035519 ITS chuck 100 P 102 x 102



Version	Steel, hardened.
Clamping power	6000 N.
Connections	On the side or at the rear, with two lines.
Operation	With control unit or with air jet.
Application	For receiving pallets $\varnothing 115 / \varnothing 148$, electrode holders, pallets PM56, PM60 and PM85 Precise.

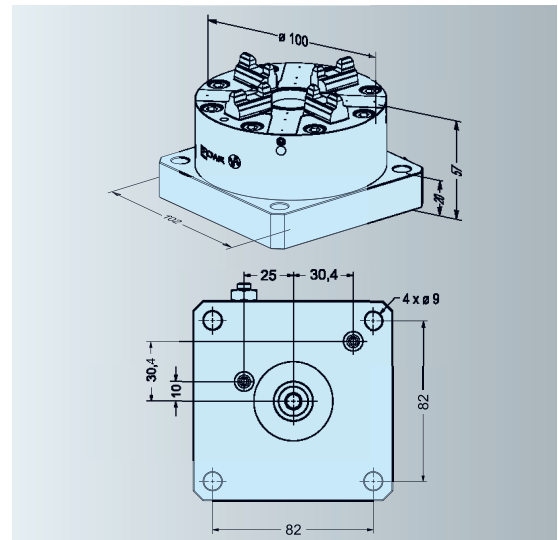

ER-045076 ITS chuck 100 P 118 x 118



Version	Steel, hardened.
Clamping power	6000 N.
Connections	Laterally or at the rear, with two lines.
Operation	With control unit or compressed-air jet.
Application	For receiving pallets $\varnothing 115 / \varnothing 148$, electrode holders, pallets PM56, PM60 and PM85 Precise.

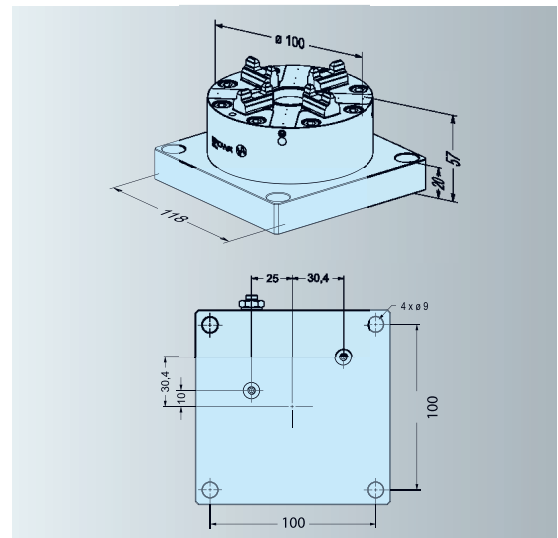

EROWA ITS chucks

pneumatic, table, manual

ER-012299 Rapid-action chuck NSF on plate



Version NSF = increased clamping power up to 7000 N.
 Connections Pneumatic valves on side.
 Application Electrode fabrication, e.g. on magnetic plate.
 Note To hold pallets $\varnothing 115 / \varnothing 148$, electrode holders, with the exception of pallets with a P-profile.

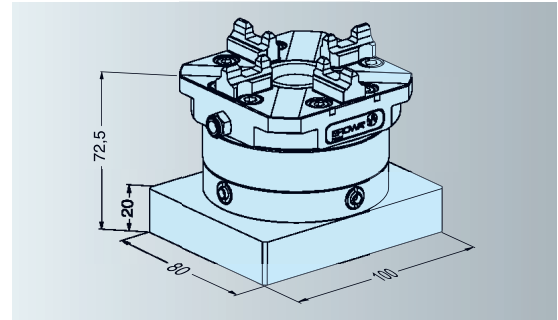

ER-012297 Rapid-action chuck NSF on block



Version NSF = increased clamping power up to 7000 N.
 Connections Pneumatic valves on side.
 Application Electrode fabrication. For use in horizontal and vertical positions.
 Note To hold pallets $\varnothing 115 / \varnothing 148$, electrode holders, with the exception of pallets with a P-profile.

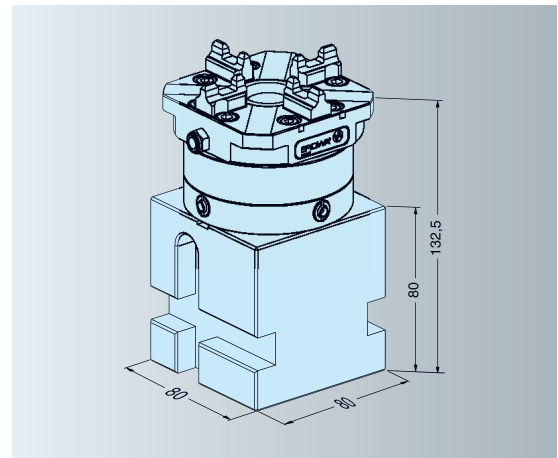

ER-007612 Rapid-action chuck NSF on angle plate



Version Standard type on type G angle plate.
 NFS = increased clamping power up to 7000 N.
 Connections Pneumatic valves on the side, flushing through chucking spigot.
 Application To produce electrodes, and on EDM quill.
 Note To hold pallets $\varnothing 115 / \varnothing 148$, electrode holders, with the exception of pallets with a P-profile.

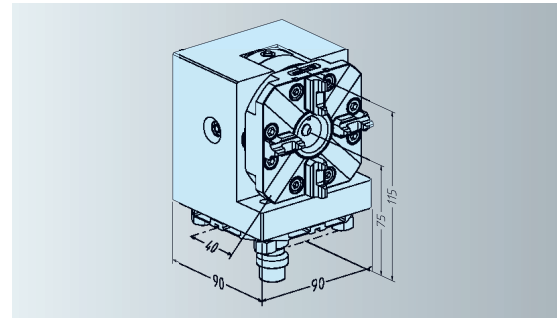

EROWA ITS chucks

pneumatic, table, able to automate, INOX

ER-043123 ITS chuck 100 P Inox without base plate



Version	Steel, hardened, INOX.
Clamping power	5000 N.
Connections	At the rear, with two lines.
Operation	With control unit
Note	To hold pallets $\varnothing 115 / \varnothing 148$, electrode holders and pallets PM56, PM60 and PM85 Precise.

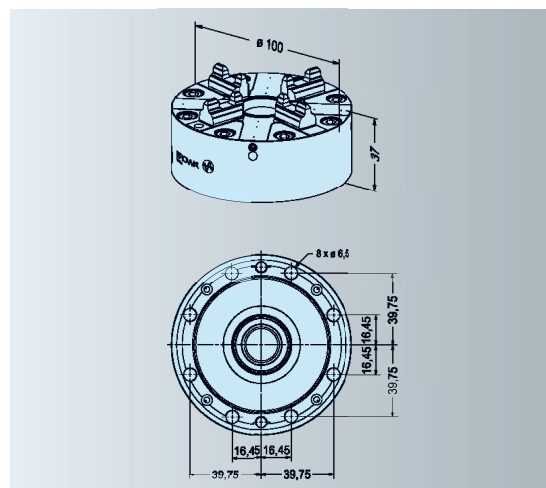

ER-043124 ITS chuck 100 P Inox 102 x 102



Version	Steel, hardened, INOX.
Clamping power	5000 N.
Connections	On the side or at the rear, with two lines.
Operation	With control unit or with air jet.
Application	To hold pallets $\varnothing 115 / \varnothing 148$, electrode holders and pallets PM56, PM60 and PM85 Precise.

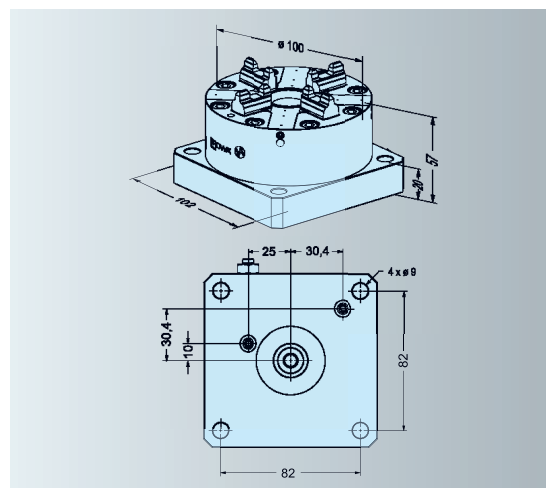

ER-047743 ITS chuck 100 P Inox 118 x 118



Version	Steel, hardened, stainless
Clamping power	5,000 N
Connections	Laterally or at the rear, with two lines.
Operation	With control unit or with compressed-air jet.
Application	To hold pallets $\varnothing 115 / \varnothing 148$, electrode holders and pallets PM56, PM60 and PM85 Precise.

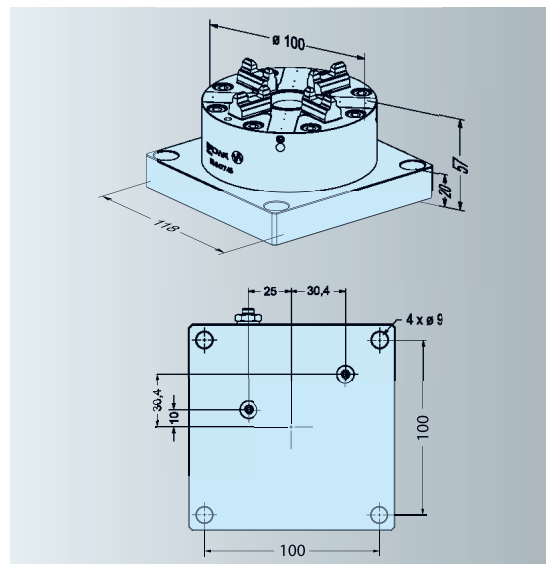

EROWA ITS chucks

pneumatic, table, able to automate, INOX

ER-048519 ITS chuck 50 Inox



Version	System size 50, corrosion-resistant.
Clamping power	2800 N.
To be fitted	with 8 M5 bolts from the front.
Application	For fixtures produced by users themselves.
Note	Chuck can be operated manually or automatically. Air connections laterally or at the rear.

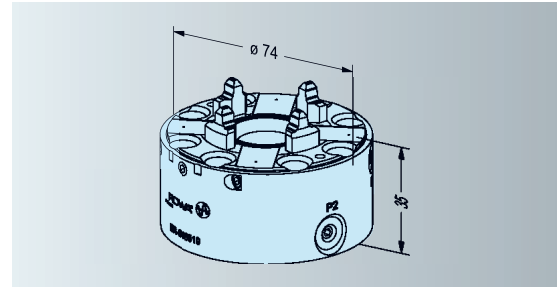

ER-055294 ITS Chuck 50 Inox with base plate 80 x 120



Version	System size 50, corrosion-resistant.
Clamping power	2800 N.
Attachment	With 4xM8 bolts from the front.
Application	On milling and grinding machines and on EDM/WEDM centers.
Note	Chuck can be operated manually or automatically. Pneumatic connections on the side of the chuck.

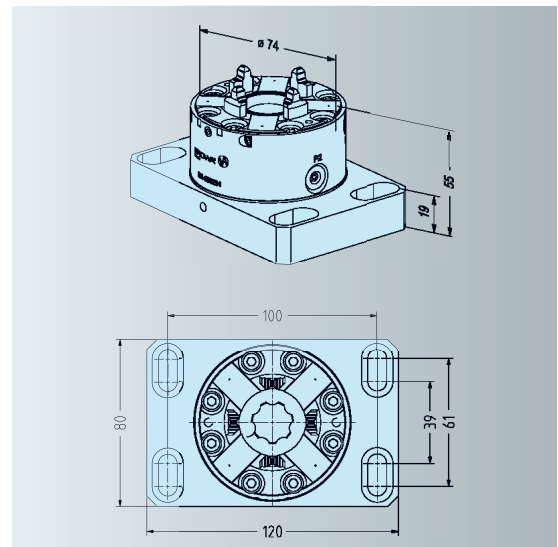

ER-011803 Chuck 50 RSA without base plate



Version	Chuck 50 RSA, automatic with pneumatic valve.
Clamping power	2800 N.
Attachment	With 4 M6 bolts from the rear.
Application	ITS basis for the manual loading of ITS elements or for automatic operation.

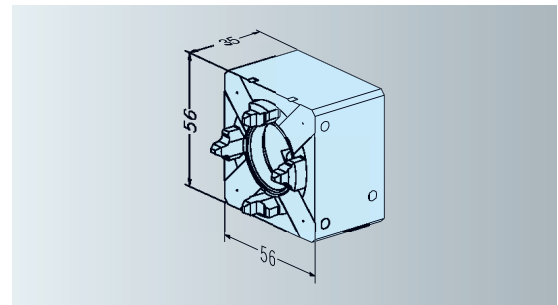

ER-008186 Chuck 50 RSA with base plate 10 x 55.5 x 85



Version	Chuck 50 RSA, automatic, with pneumatic connection.
Clamping power	2800 N.
Application	ITS basis for the manual loading of ITS elements or for automatic operation.

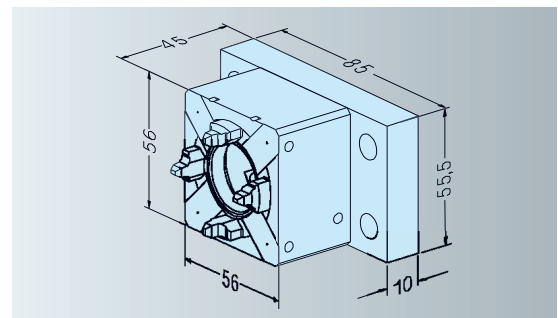

EROWA ITS chucks

manual, quill

Technical data	ITS chuck, manual
Repeatability	0.002 mm
Indexing	4 x 90°
Operation/clamping	manually with clamping lever

ER-038826 QuickChuck 100 P / R



Version	On a $\varnothing 110$ mm base plate with a rotatable flushing connection.
Attachment	With 4 x M6 bolts.
Application	On EDM centers with quill rotation.
Note	Clamping power: up to 10000 N.

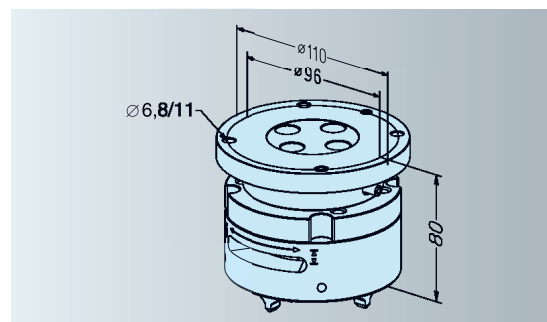

EROWA ITS chucks manual, table, INOX

ER-034387 QuickChuck 50



Version	System size 50, manual, corrosion-resistant.
Attachment	4 x M8 from the rear or 4 x M6 stud bolts with nuts.
Application	On EDM/WEDM centers for light milling and grinding work. Max. revolutions on rotating axes 200min ⁻¹
Note	Clamping power up to 4000 N.

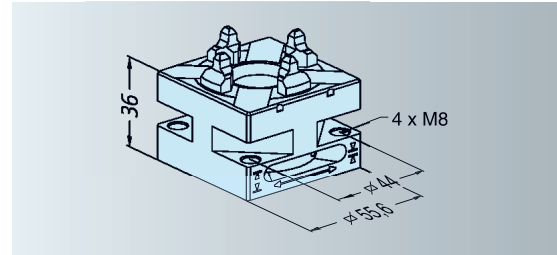

ER-036345 QuickChuck 100 P



Version	System size 100, manual, corrosion-resistant.
Mounting	With four M8 bolts supplied.
Application	Turning, milling, grinding or EDM/WEDM machines, in dividers and fixtures.
Note	Clamping power up to 10000 Nm. max. 3000 rpm.

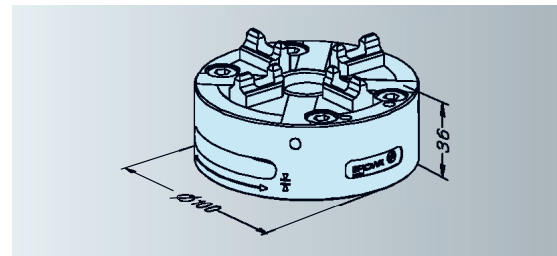

ER-038824 QuickChuck 100 P with base plate



Version	System size 100, manual, corrosion-resistant, with baseplate.
Mounting	With bolts or clamps.
Application	Milling, grinding or EDM machines.
Please note	Clamping power up to 10000 N.

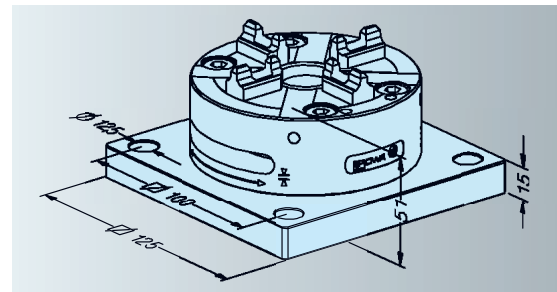

EROWA ITS chucks

ITS screw chucks

manual

Technical data	ITS screw chuck, manual
Repeatability	0.002 mm
Indexing	4 x 90°
Operation/clamping	manually with locking bolt

ER-007697 Screw chuck 50 D



- Version Only 20 mm overall height. For holders of system size 50.
- Connections Central flushing possible.
- Application Small lathes, on tapers, flanges, jigs and fixtures.

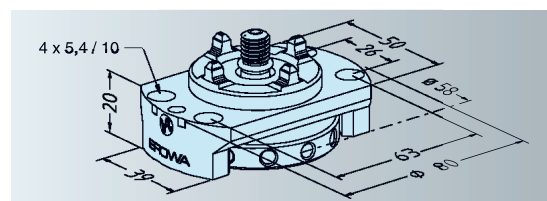

EROWA ITS chucks

Accessories

ER-019424 Universal square block



Version	Steel, hardened, corrosion-resistant.
Application	For attaching 1 or 2 chucks in horizontal and/or vertical position. Fits ITS chucks, QuickChuck 50, QuickChuck 100.
Note	Delivery without chucks.

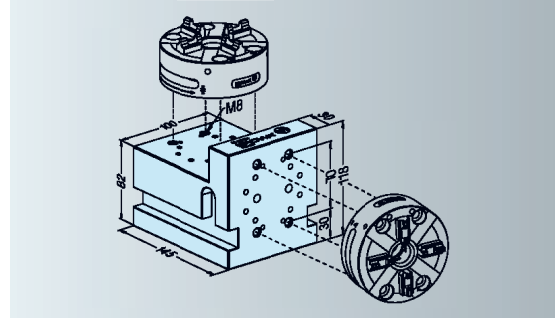

ER-032832 Sealing ring ITS chuck 50



Version	Plastic.
Application	Prevents penetration of chips and dirt into the ITS Chuck 50 by application of EROWA Holders $\varnothing 72$.

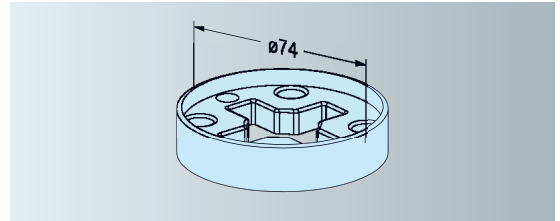

ER-034665 Cover ITS chuck 50



Version	Aluminium anodized. Without centering plate.
Application	Prevents penetration of chips and dirt into the ITS Chuck 50 in combination with the seal ring ER-032832.

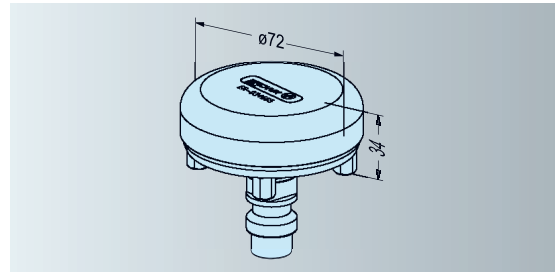

ER-094955 Sealing ring ITS 50 C for chuck 50



Version	Plastic.
Application	Prevents penetration of chips and dirt into the ITS Chuck 50 with application of EROWA Holders ITS50 C.

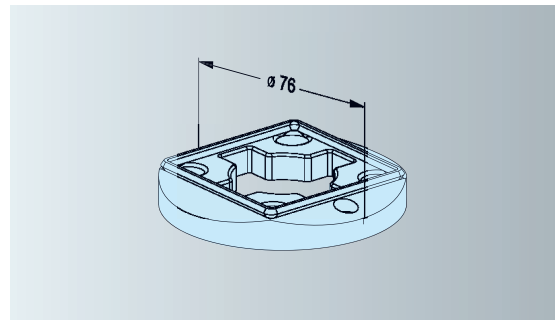

ER-094152 Sealing ring ITS50 C for ITS 100 P manual



Version	Aluminium anodized.
Application	Prevents penetration of chips and dirt into the QuickChuck 100 P or ITS chuck 100 P by application of EROWA electrode holders C.

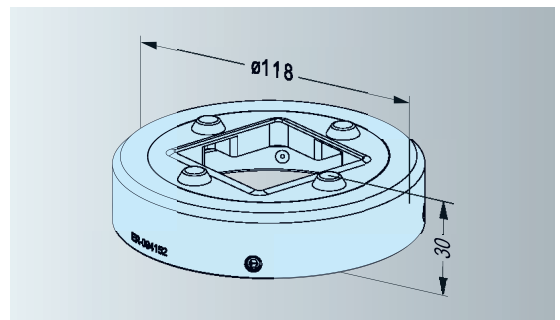

ER-034735 Seal Rapid Action Chuck / ϕ 72

Version Aluminium anodized.
 Application Prevents penetration of chips and dirt into the rapid action chuck by application of EROWA Holders ϕ 72.

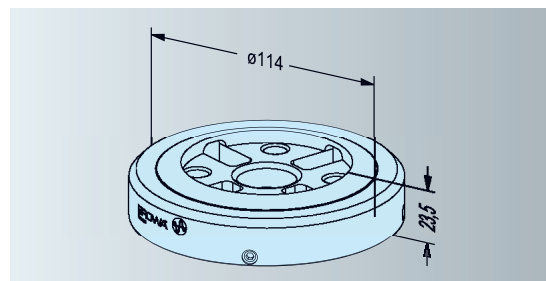
**ER-035356 Sealing ring QuickChuck 100 P ϕ 72**

Version Aluminium anodized.
 Application Prevents penetration of chips and dirt into the QuickChuck 100 P or ITS chuck 100 P by application of EROWA Holders ϕ 72.

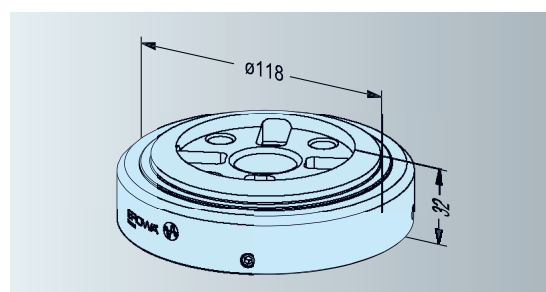
**ER-094112 Sealing ring ITS50 C for SSF manual**

Version Aluminium anodized.
 Application Prevents penetration of chips and dirt into the rapid action chuck during machining of EROWA electrode holders C.

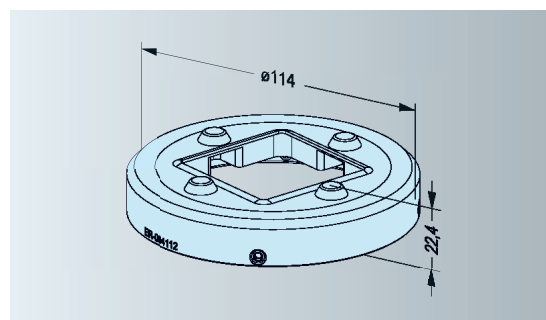
**ER-046046 Chip guard ϕ 115 to QuickChuck 100 P / ITS Chuck 100 P**

Version Aluminum, for pallets ϕ 115 mm.
 Application Seals QuickChuck 100 P / ITS Chuck 100 P in use with pallets ϕ 115 mm against liquid and chips. Can be combined with ER-029313.

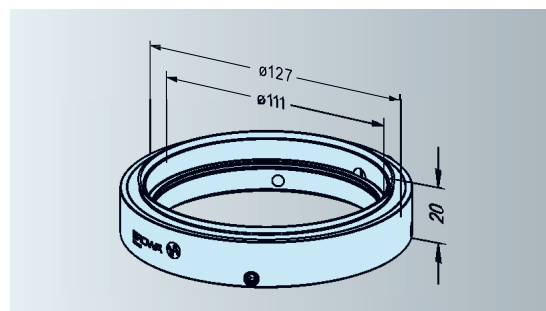
**ER-046044 Chip guard ϕ 148 for QuickChuck 100 P / ITS Chuck 100 P**

Version Aluminum, for pallets ϕ 148 mm.
 Application Seals QuickChuck 100 P / ITS Chuck 100 P in use with pallets ϕ 148 mm against liquid and chips. Can be combined with ER-029313.

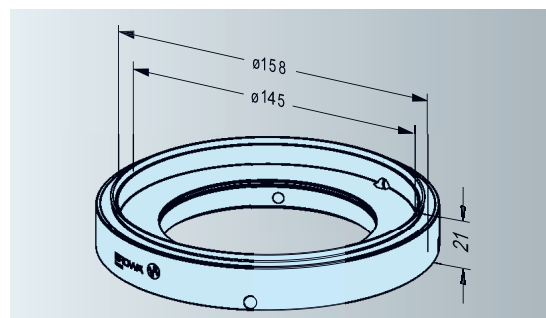

EROWA ITS chucks

Accessories

ER-029313 Chip guard for QuickChuck 100 P



Version Aluminum.
Application Seals the locking mechanism of the QuickChuck 100 P against the penetration of liquids and chips.

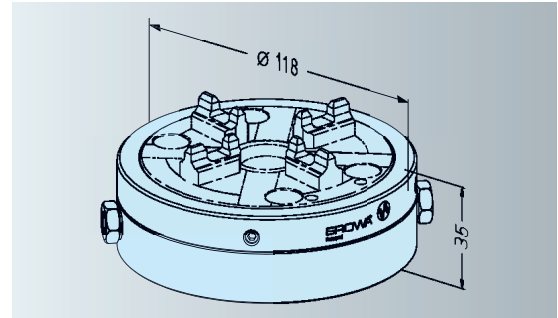

ER-007618 Cover for rapid-action chuck



Version Aluminum, without supports and centering plate.
Application To protect rapid-action chucks against dirt.

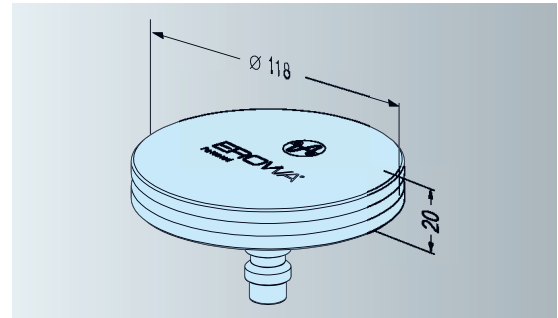

ER-041374 Sealing ring PM56



Version Aluminum, for pallets PM56.
Application Prevents dirt from penetrating into ITS chuck 100 P.

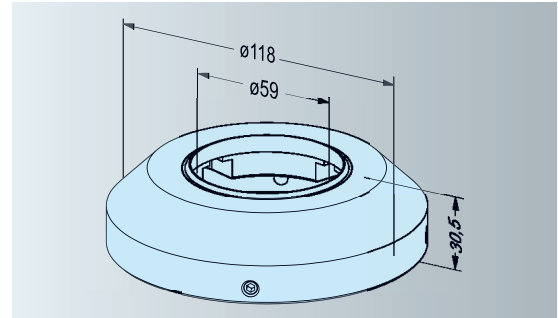

ER-034677 Sealing ring ITS 100 P / ø 85



Version Aluminum, for pallets PM85.
Application Prevents dirt from penetrating into ITS chuck 100 P.

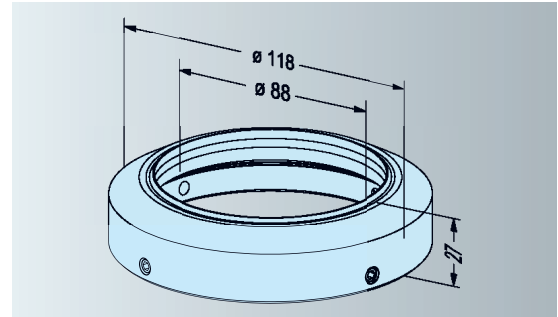



EROWA ITS System carriers

The components

Universality starts with the system carrier. Whether you use completely prepared electrode holders, pallets or the very economically priced centering plates, they all depend on the application. However, the workpiece will be ready for universal and flexible use in any case.

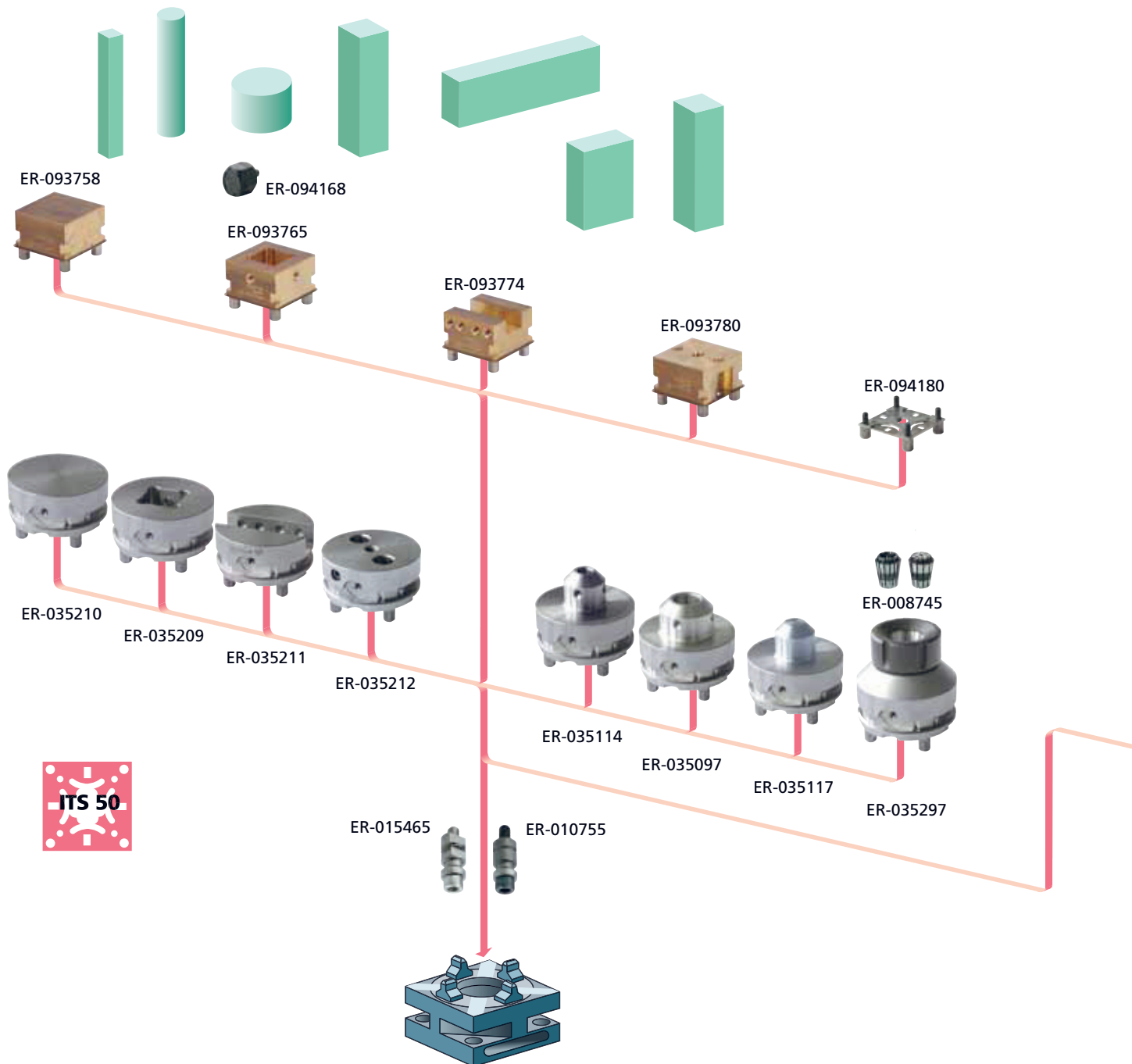

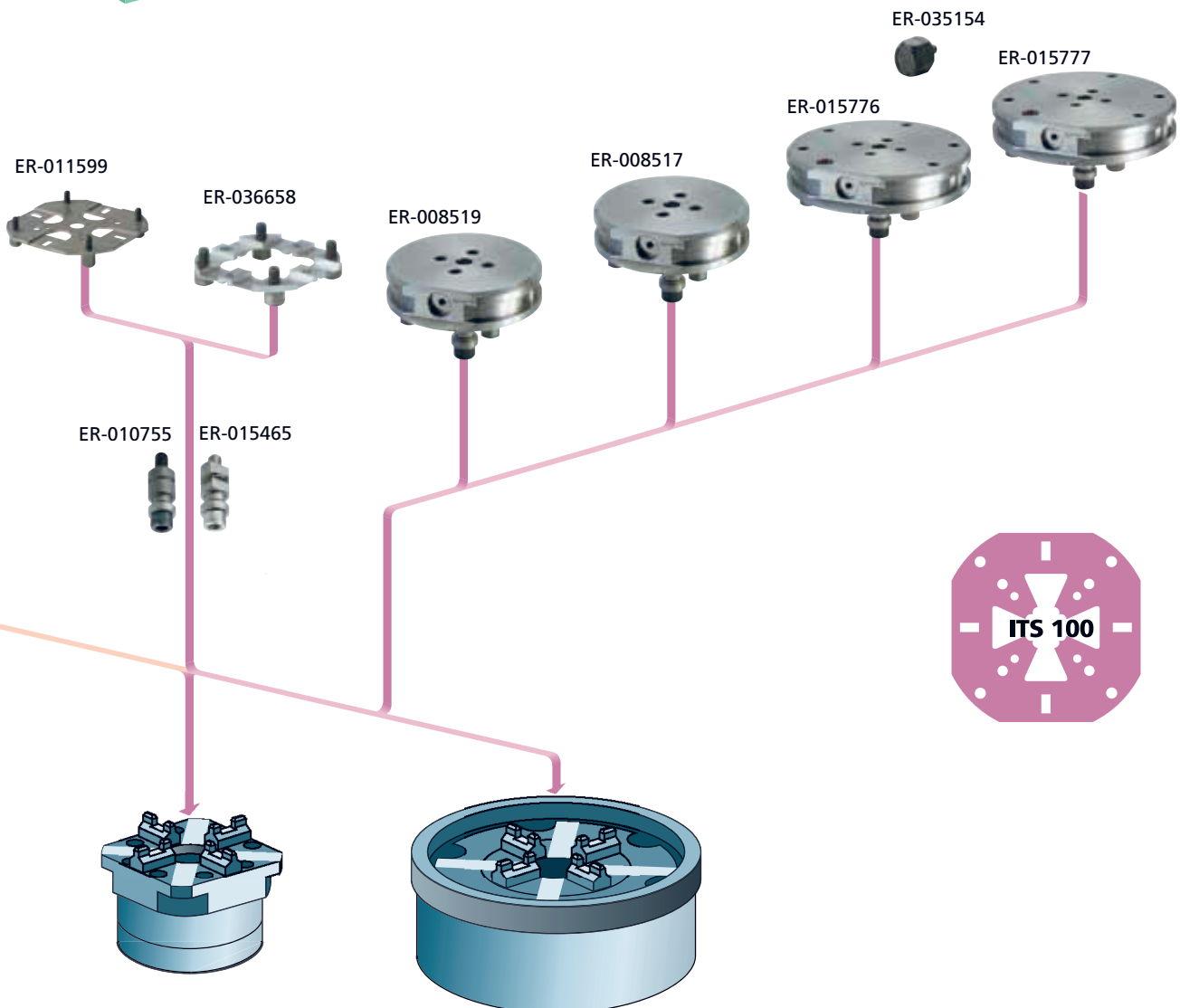
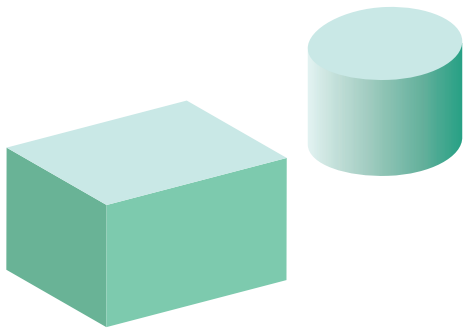

ITS

EROWA ITS System carriers

ITS centering plates

The centering plates are the most cost-effective base for clamping electrodes. They are mounted directly onto the blanks. This way, jigs and fixtures are also ITS compatible. The hole pattern for mounting is simply drilled into the blank with a drilling template, or by means of an NC program.

Technical data	ITS centering plates
Material	corrosion-resistant
System accuracy in chuck	0.002 mm
Versions:	
Centering plate 50	small electrode weights
Centering plate 100 M8	workpieces and electrodes
Centering plate G	workpieces, jigs and fixtures for chip-removal machining
Handling	with EROWA Handlingsystems or electrode changer.

ER-094180 Centering plate 50 C
50 pieces

ER-094181 Centering plate 50C
5 pieces



Version Corrosion-resistant, including sealing plate and 4 supporting feet each.
Application Small electrode weights.
Mounting Mounted directly on plane surface of blank.

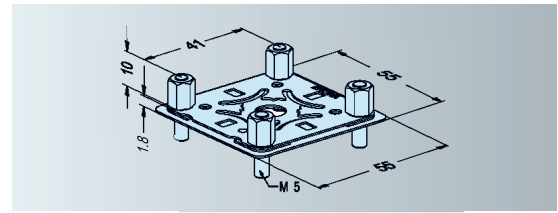

ER-011599 Centering plate 100 M8
10 pieces

ER-050195 Centering plate 100 M8
1 unit



Version Corrosion-resistant, including 4 supporting feet M8 and 4 x M5 screws per plate.
Application Workpieces and electrodes.
Mounting Mounted directly on of blank plane surface of blank.

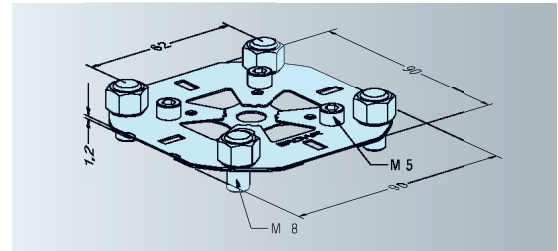

ER-036658 Centering plate G Inox
5 pieces

ER-036657 Centering plate G Inox
1 unit



Version Ground, including 8 supporting feet M8.
Application For workpieces, jigs and fixtures in chip-removal machining.
Fixation of blank According to accompanying fitting instructions.

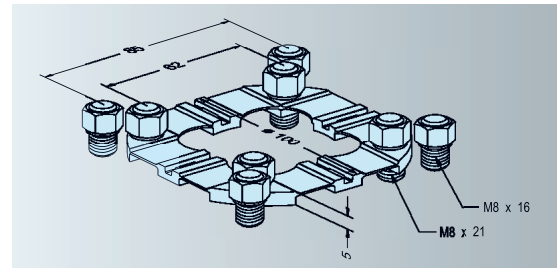

EROWA ITS System carriers

ITS standard electrode holders

Standard electrode holders are used to contain electrodes for the entire machining cycle and for storage. Their economical unit price enables users to stock such holders in large quantities. The standard holders are supplied without chucking spigots.

Technical data	ITS standard electrode holders
Material	body: brass centering plate: corrosion-resistant
System accuracy in chuck	0.002 mm
Recommended max. weight with electrode	20 kg / 44 lbs
Handling	with EROWA Handlingsystems or electrode changer.

ER-093758 Uniblack C EWIS™ 12 pieces



Version	Set of 12 units, fitted without machining of body. With gripper slot and sealing plate.
Application	To mount electrodes and workpieces of various shapes.
Mounting	As required.
Note	Order EWIS™ chip, ER-094168 separately.

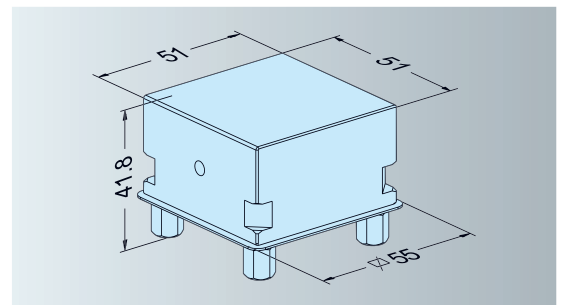

ER-093765 Prisround C EWIS™ 12 pieces



Version	Set of 12 units, with gripper slot and sealing plate. Prepared for receiving the code carrier.
Application	To mount blank parts with shaft size up to 25 mm
Mounting	Fit into recess and tighten bolts. If necessary center part with insert plates ER-010523.
Note	Order EWIS™, ER-094168 separately!

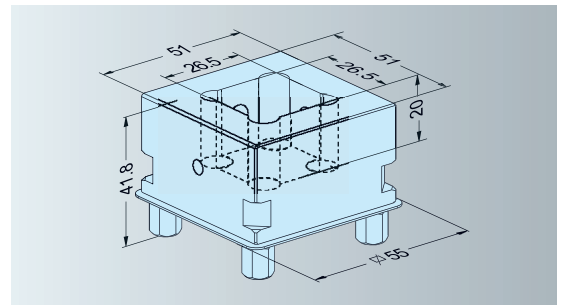

ER-093774 Uniholder C EWIS™ 12 pieces



Version	Set of 12 units, including 2 setscrews for each unit. With gripper slot and sealing plate.
Application	To mount electrodes and workpieces with a base surface of up to 20 mm.
Mounting	Insert and tighten setscrews. If necessary, center with spacer plate ER-010532.
Note	Order EWIS™ chip, ER-094168 separately!

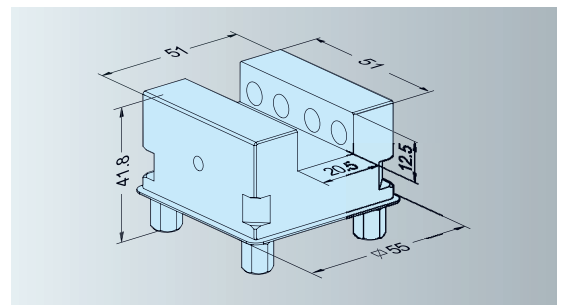

EROWA ITS System carriers

ITS standard electrode holders

ER-093780 Uniplate C EWIS™ 12 pieces



- Version Set of 12 units, surface 51 x 51 mm faced, including 2 x M6 bolts for each unit. With gripper slot and sealing plate.
- Application To mount electrodes and workpieces with a base surface of more than 50 mm.
- To fit blank With 2 x M6 bolts into the base surface.
- Note Order EWIS™ chip, ER-094168 separately.

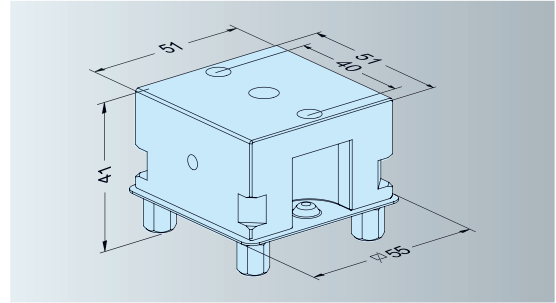

ER-010627 Uniplate Alu 80 x 80 4 pieces



- Version Set of 4 units, aluminum, system size 100, with M8 supports.
- Application To mount electrodes and workpieces with a base surface of more than 70 mm.
- Mounting With 4 x M6 bolts into the base surface.

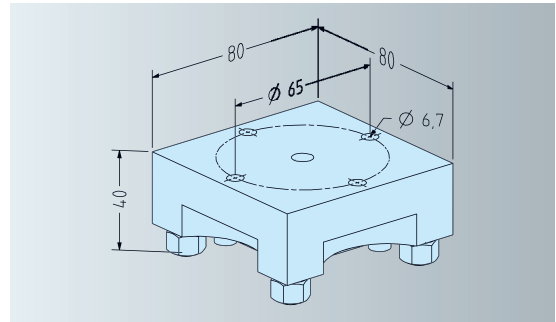

ER-010532 Spacer plate 300 pieces



- Version 6 x 50 plates. Corrosion-resistant. Thicknesses from 0.5 mm to 5 mm.
- Application Centering of blanks in electrode holders.

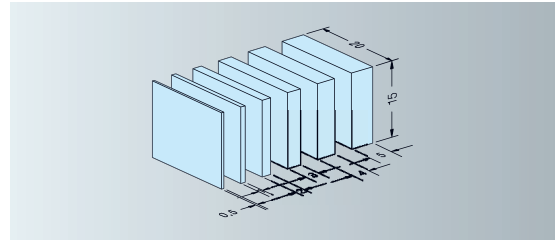

ER-013913 System stand 10 pieces

- Version Plastic, set of 10.
- Application As a rack for four electrode holders 50 or a pallet \varnothing 115/148 mm.
- Please note System racks can be stuck together without any gaps, e. g. to be stored in drawers.

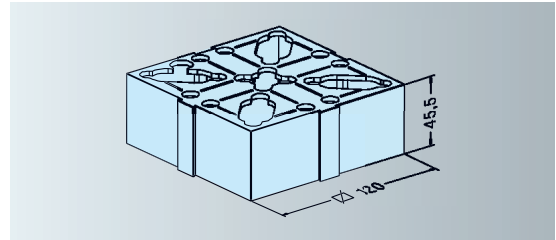

ER-011591 System stand 50 12-fold 10 pieces

- Version Set of 10 styrene stands.
- Application Storage and transport of electrode holders system size 50.

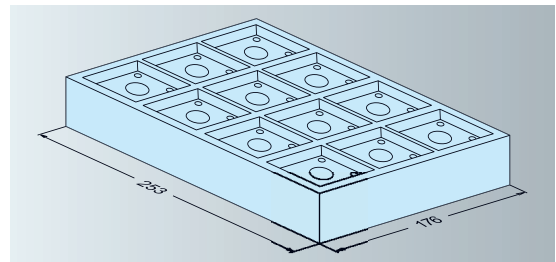

EROWA ITS System carriers

Holder $\varnothing 72$

The EROWA holders $\varnothing 72$ in combination with covers provides maximum protection against the contamination of table chucks. The holders are the optimal solution for automatic production.

Technical data	EROWA Holder $\varnothing 72$
Material	steel, corrosion-resistant
System accuracy, chuck	0.002 mm
Recommended max. weight with electrode	20 kg / 44 lbs
Handling	with EROWA handling systems or electrode changers.

**ER-035210 Uniblack $\varnothing 72$
6 pieces**

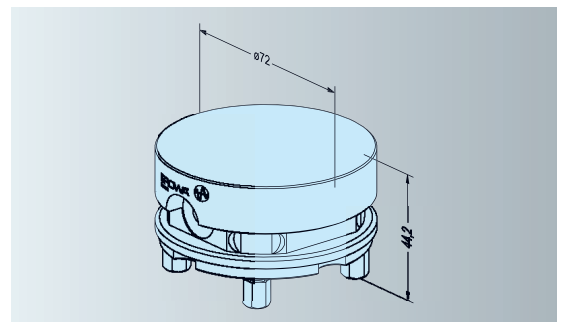

Version	Set of 6 units, system size ITS 50. Without chucking spigots.
Application	To mount electrodes and workpieces of various shapes.
Mounting	Attachment boreholes to be drilled according to requirements.

**ER-035209 Prisround $\varnothing 72$
6 pieces**

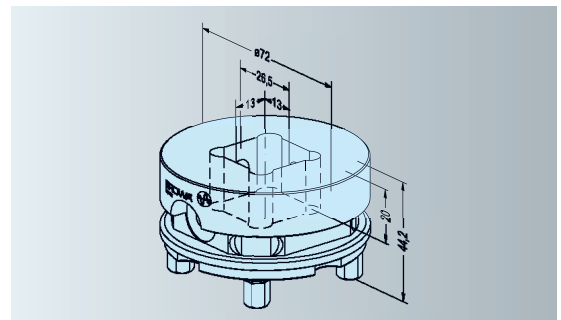
Version	Set of 6 units, system size ITS 50. Without chucking spigots.
Application	To mount electrodes and workpieces with shafts of up to square 25 mm.

**ER-035211 Uniholder $\varnothing 72$
6 pieces**

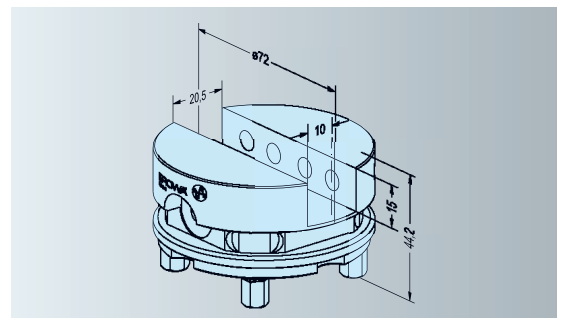
Version	Set of 6 units, system size ITS 50. Without chucking spigots.
Application	To mount electrodes and workpieces with shaft of up to 20 mm.



EROWA ITS System carriers

Holder \varnothing 72

ER-035212 Uniplate \varnothing 72 6 pieces



Version Set of 6 units, includes 12 PinLock locking pins. System size ITS 50, without chucking spigots.

Application To mount electrodes and workpieces with surface more than square 40 x 40 mm or \varnothing 50 mm.

Mounting With two PinLock locking pins.

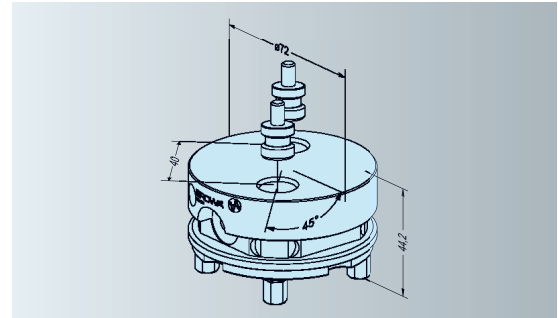

ER-035114 Blank holder \varnothing 10 / \varnothing 72 6 pieces



Version Set of 6 units, system size ITS 50. Without chucking spigots.

Application To clamp cylindrical parts with \varnothing 10 mm.

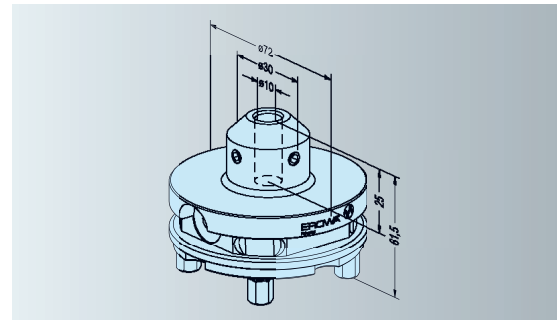

ER-035097 Blank holder \varnothing 20 / \varnothing 72 6 pieces



Version Set of 6 units, system size ITS 50. Without chucking spigots.

Application To clamp cylindrical parts with \varnothing 20 mm.

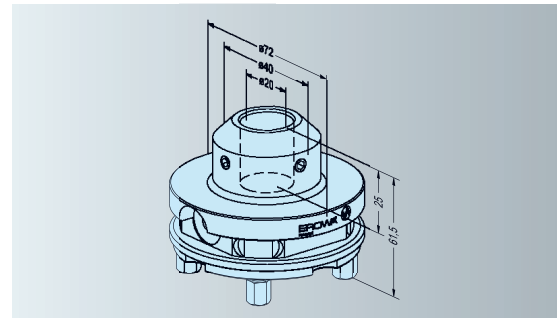

ER-035117 Blank holder \varnothing 72 without borehole 6 pieces



Version Set of 6 units, system size ITS 50. Without chucking spigots.

Application To clamp cylindrical parts.

Mounting Attachment borehole up to max. \varnothing 12 mm to be drilled according to requirements.

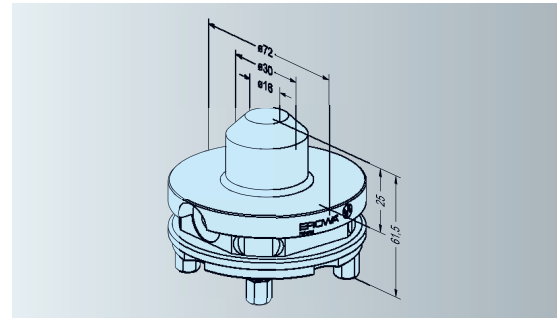

ER-035297 Collet chuck holder \varnothing 72 1 piece



Version One collet chuck holder with chucking spigot. System size ITS 50.

Application To clamp cylindrical parts. Clamping range \varnothing 2 mm - \varnothing 20 mm.

Please note Order collet chucks type ETS 32 separately.

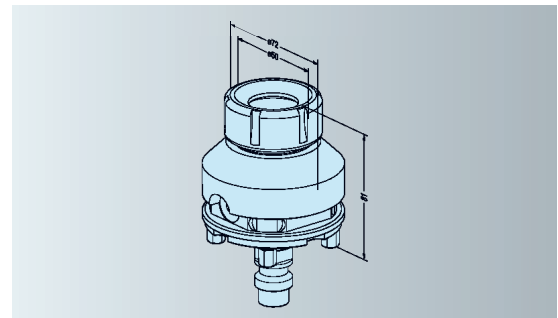



EROWA ITS System carriers

ITS precision pallets

ITS precision pallets are workpiece and electrode carriers.
The pallets are prepared for automatic handling and to accommodate EWIS chips. Marginal and night hours are thus put to productive use.

Technical data	ITS precision pallets
Material	corrosion-resistant
System accuracy in chuck	0.002 mm
Run-out	< 0.01 mm
Variants	
Pallets MS	die cut centering plates
Pallets G	ground centering plates
Pallets P	Centering integrated in the pallet
Borehole pattern	standard, can be supplemented
Handling	with EROWA Handlingsystems
Unit supplied	pallet including chucking spigot

ER-008519 Pallet \varnothing 115 MS EWIS™

ER-032730 Pallet kit \varnothing 115 MS 4 pieces



Version Standard type, punched centering plates.
 Application For electrodes and workpieces in EDM
 Mounting Through pallet with 4xM8 bolts or through blank with 4xM10 bolts.

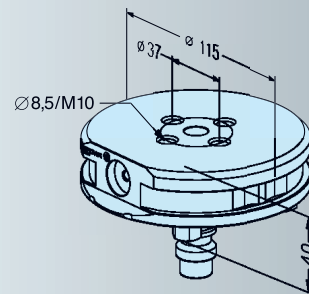

ER-008517 Pallet G \varnothing 115 EWIS™

ER-032729 Pallet kit G \varnothing 115 4 pieces



Version Standard type, ground centering plates.
 Application For electrodes and workpieces in EDM.
 Mounting Through pallet with 4xM8 bolts or through blank with 4xM10 bolts.

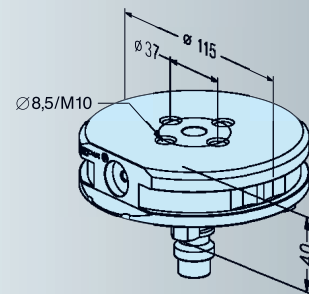

ER-015776 Pallet \varnothing 148 MS EWIS™

ER-032731 Pallet kit \varnothing 148 MS 4 pieces



Version Standard type, punched centering plates.
 Application For electrodes and workpieces, and for the construction of fixtures.
 Mounting Through pallet with M8 bolts or through blank with M10 bolts.

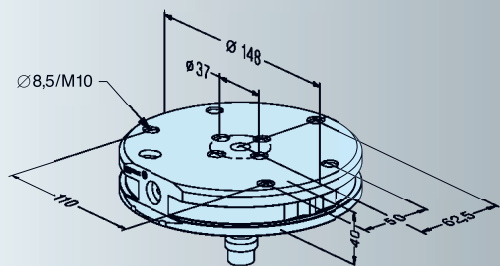

ER-015042 Pallet \varnothing 148 MS ALU R25**ER-033051 Pallet Kit \varnothing 148 MS ALU R25
4 pieces**

- Version Body of casted aluminum with borehole pattern 25, \varnothing 10 F7, thread M10.
- Application Palletizing of workpieces and electrodes, mounting of fixtures and ClampSet Base 220.
- Mounting Through pallet with M8 bolts or through blank with M10 bolts.

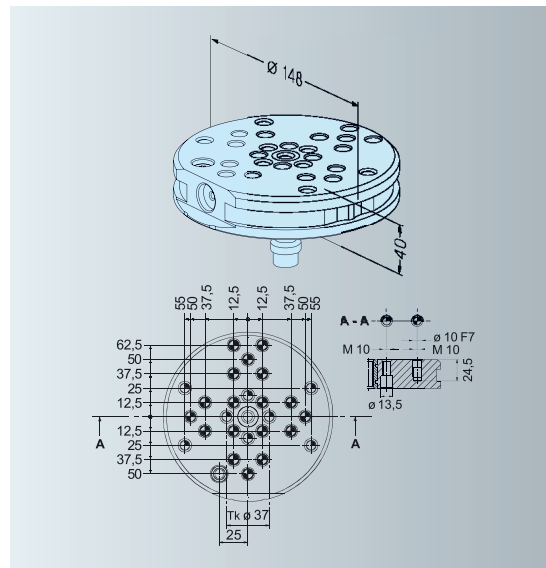
**ER-032699 Pallet \varnothing 148 G****ER-033048 Pallet Kit \varnothing 148 G
4 pieces**

- Version Without bore holes apart from center borehole and borehole for reference bolt.
- Application For work pieces machined in chip-cutting machining.
- Mounting According to your preference.

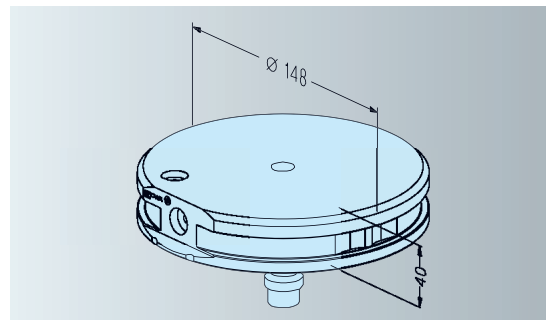
**ER-015777 Pallet \varnothing 148 G EWIS™****ER-032732 Pallet kit G \varnothing 148 EWIS™
4 pieces**

- Version Standard type, ground centering plates.
- Application To accommodate workpieces and fixtures in chip-cutting machining processes.
- Mounting Through pallet with M8 bolts or through blank with M10 bolts.

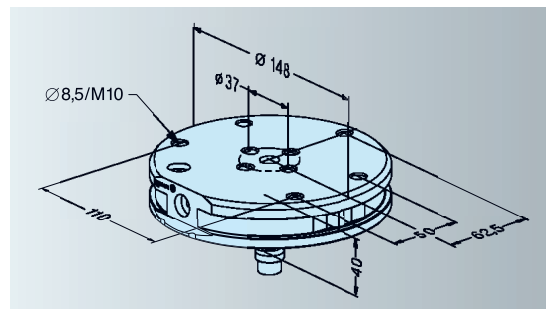

EROWA ITS System carriers

ITS precision pallets

ER-015899 Pallet \varnothing 148 G R25

**ER-033053 Pallet Kit \varnothing 148 G R25
4 pieces**



- Version Steel, nitride coated, with borehole pattern 25, \varnothing 10 F7, thread M10.
- Application To accommodate EROWA ClampSet Base 220 or specially constructed fixtures and gauges.

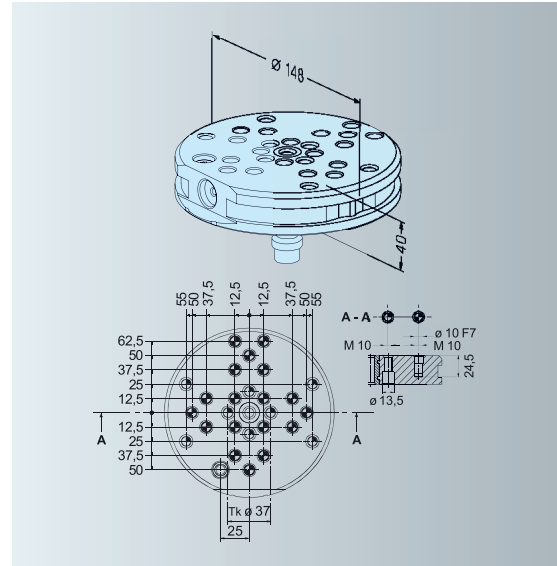

ER-041912 Pallet P \varnothing 148 Inox

**ER-041924 Pallet Kit P \varnothing 148 Inox
4 pieces**



- Version Steel, corrosion-resistant. Centering integrated in the pallet.
- Application For use on all EROWA PowerChucks P and Production-Chuck 210 Combi. To accommodate workpieces and fixtures in chip-cutting machining processes.
- Mounting Through pallet with M8 bolts or through blank with M10 bolts.

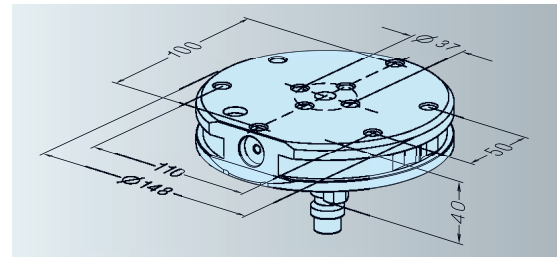

**ER-068585 Manual 3-jaw concentric chuck \varnothing 125mm
on pallet \varnothing 148 G**



- Version Manual 3-jaw concentric chuck \varnothing 125mm. Central clamping range 3-53mm. Body made of cast metal. High degree of concentricity according to DIN 6386. Fitted to pallet \varnothing 148 G. Includes 3 hardened drilling jaws (stepped on the outside), 3 hardened turning jaws (stepped on the inside) 1 spanner.
- Note Max. speed 4000 min⁻¹.
- Application In combination with EROWA chucks on lathes, indexing tables, dividing heads, etc.
- Spare parts Block jaws, soft, for 3-jaw chuck, set of 3, size 125mm.

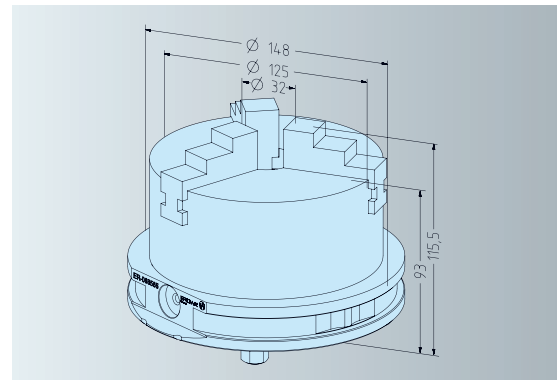

ER-068586 Manual 4-jaw concentric chuck \varnothing 125mm on pallet \varnothing 148 G

Version Manual 4-jaw concentric chuck \varnothing 125mm. Central clamping range 3-53mm. Body made of cast metal. High degree of concentricity according to DIN 6386. Fitted to pallet \varnothing 148 G. Includes 4 hardened drilling jaws (stepped on the outside), 4 hardened turning jaws (stepped on the inside), 1 spanner.

Note Max. speed 4000 min⁻¹.

Application In combination with EROWA chucks on lathes, indexing tables, dividing heads, etc.

Spare parts Block jaws, soft, for 4-jaw chuck, set of 4, size 125mm.

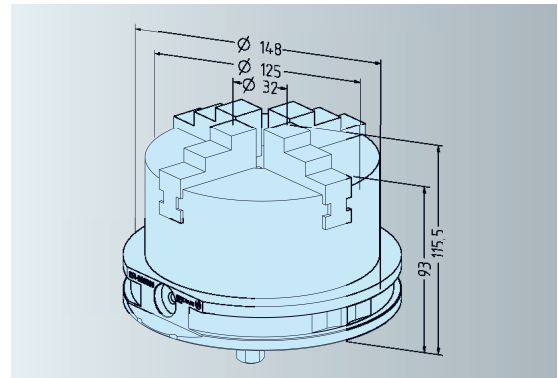
**ER-068697 Manual 3-jaw concentric chuck \varnothing 140mm on pallet \varnothing 148 G**

Version Manual 3-jaw concentric chuck \varnothing 140mm. Central clamping range 3-53mm. Body made of cast metal. High degree of concentricity according to DIN 6386. Fitted to pallet \varnothing 148 G. Includes 3 hardened drilling jaws (stepped on the outside), 3 hardened turning jaws (stepped on the inside) 1 spanner.

Note Max. speed 4000 min⁻¹.

Application In combination with EROWA chucks on lathes, indexing tables, dividing heads, etc.

Spare parts Block jaws, soft, for 3-jaw chuck, set of 3, size 140mm.

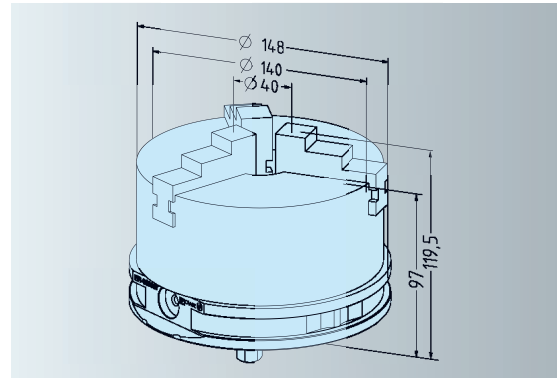
**ER-022250 Adapter pallet ITS 50 / \varnothing 148**

Version ITS system size 100.

Lock with central M 10 locking bolt.

Application To accommodate ITS Electrode holders system 50. Lock with central M10 locking bolt. For automatic handling.

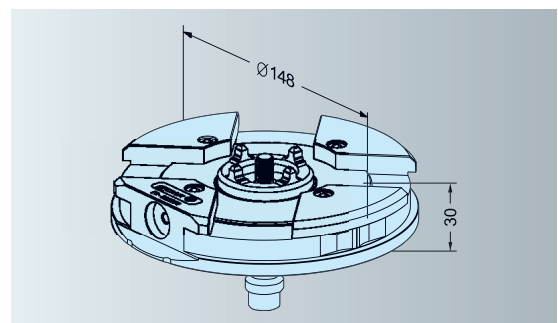

EROWA ITS System carriers

ITS precision pallets

ER-046221 Reference bolt \varnothing 7.7, M10x30 10 pieces

Version Set of 10 bolts. Bolts have been reworked.
Application On pallets \varnothing 148 mm: for positional orientation in PowerChucks and Robot magazines.

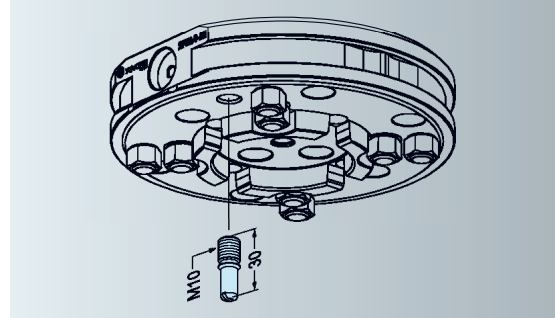

ER-035154 EWIS™ Rapid chip with chip holder SW14 with chip \varnothing 12,4 x 2mm



Version Sleeve fitting with built-in data carrier.
EWIS Rapid chip: read only.
Application In any EROWA electrode holder and pallet which has been prepared for it.

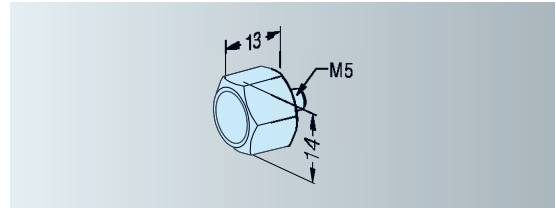

EROWA ITS Chucking spigots

For every application the proper version

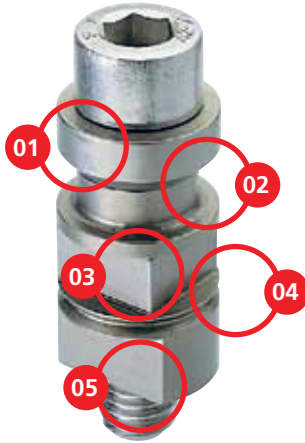

01 | Movable upper part for error compensation

02 | Groove for ball lock

03 | Flats for magazine engagement

04 | Groove for O-ring seal

05 | Flats for gripper

manual

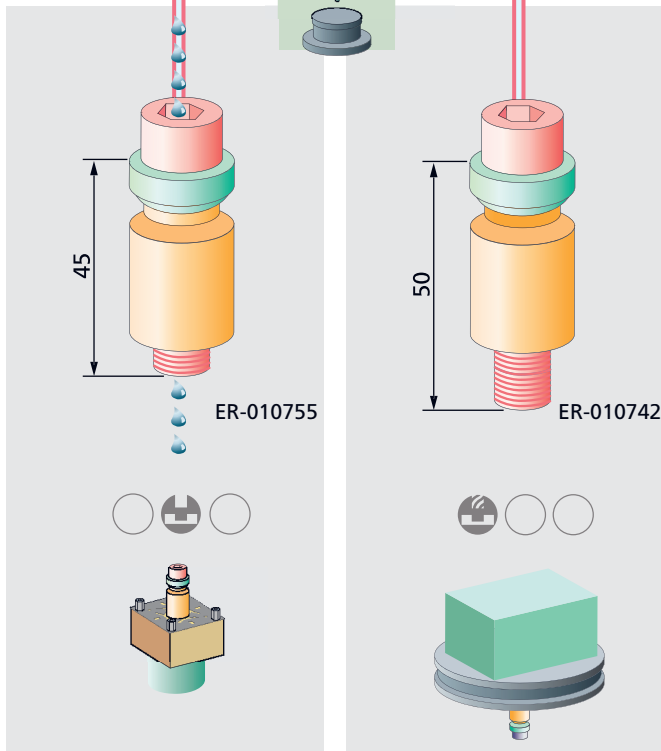

automatic

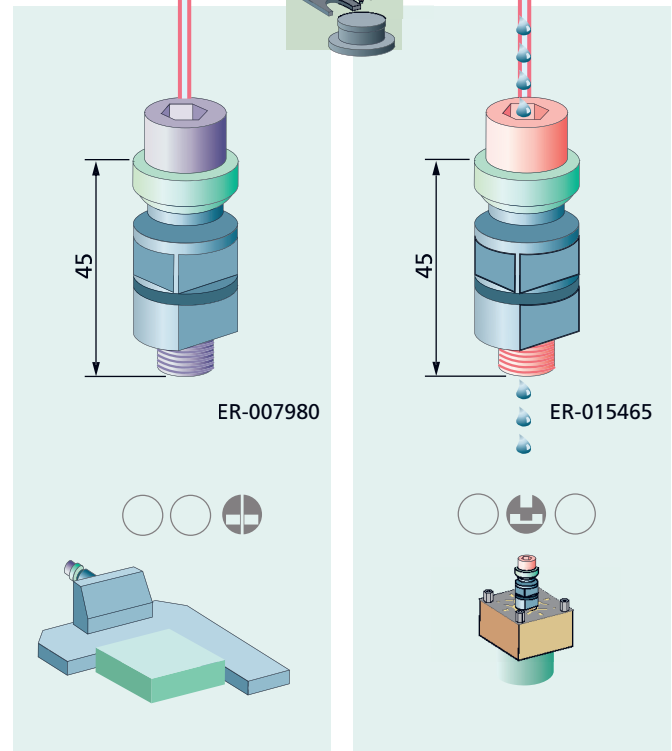

1



2



3



4



The various versions are exactly tailored to individual applications.

Chucking spigots are screwed into the holder or into the pallet for the machining cycle only. Since it has no influence on the reference position, it is removed for the purpose of spacesaving storage and only screwed in again when the holder or pallet is used next time.

Technical data	ITS Chucking spigot
Material	Steel, hardened
Bolt	M10

ER-010755 Chucking spigot F/M EDM for flushing 20 pieces



Version Fixed type, manual. Bolt with flushing hole.
Set of 20 spigots.

Application In Electrode Holders.
For EDMing and easy machining.

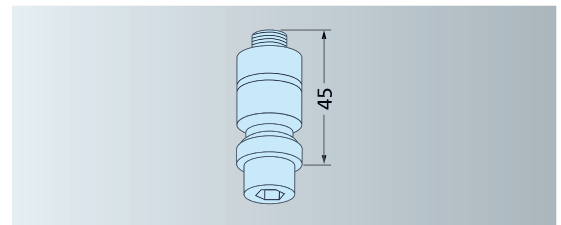

ER-010742 Chucking spigot F/M production 1 unit

ER-051381 Chucking spigot F/M Production 20 pieces



Version Fixed type, manual. Bolt 12.9, without flushing hole.

Application In pallets for chip-cutting machining processes.

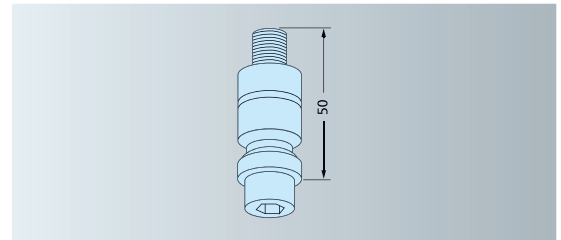

ER-007980 Chucking spigot F/A Inox 20 pieces



Version Fixed type, automatic. Bolt stainless, without flushing hole.
Set of 20 spigots.

Application On all holders used on UnoSet.

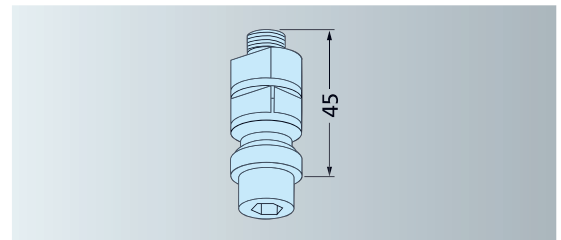

ER-015465 Chucking spigot F/A EDM M10 x 45 for flushing, 20 pieces



Version Fixed type, automatic. Bolt with flushing hole.
Set of 20 spigots.

Application For electrode holder to be changed automatically. For EDM-ing and and machining with light cutting force.

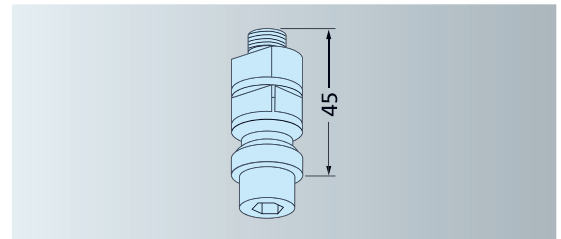

EROWA ITS Square Electrode System

Square Electrode System and System Plus

SAVE SPACE

Store up to 1600 square electrodes safe and handy on 1 m².

EROWA square holders are highly suitable for the manufacture of small electrodes. Their applications consist of milling, turning, grinding, as well as EDM sinking and WEDM. Used in addition to the System Plus, they represent a well-rounded, well thought-out range of products for everyone who works with many small electrodes.



System Plus

The stamped centering profile directly on the blank forms the system reference.

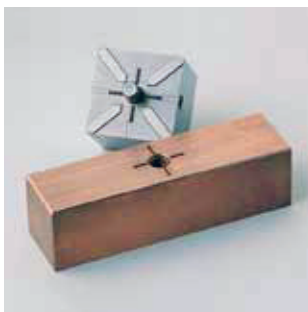

1. Preparation

Stamp in the centering profile.



2. Milling

On a straight System Plus holder.

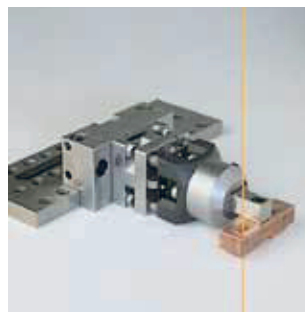

3. WEDM

On an angle holder.



4. EDM

On a straight holder.

EROWA

ITS Integrated tooling system

The components

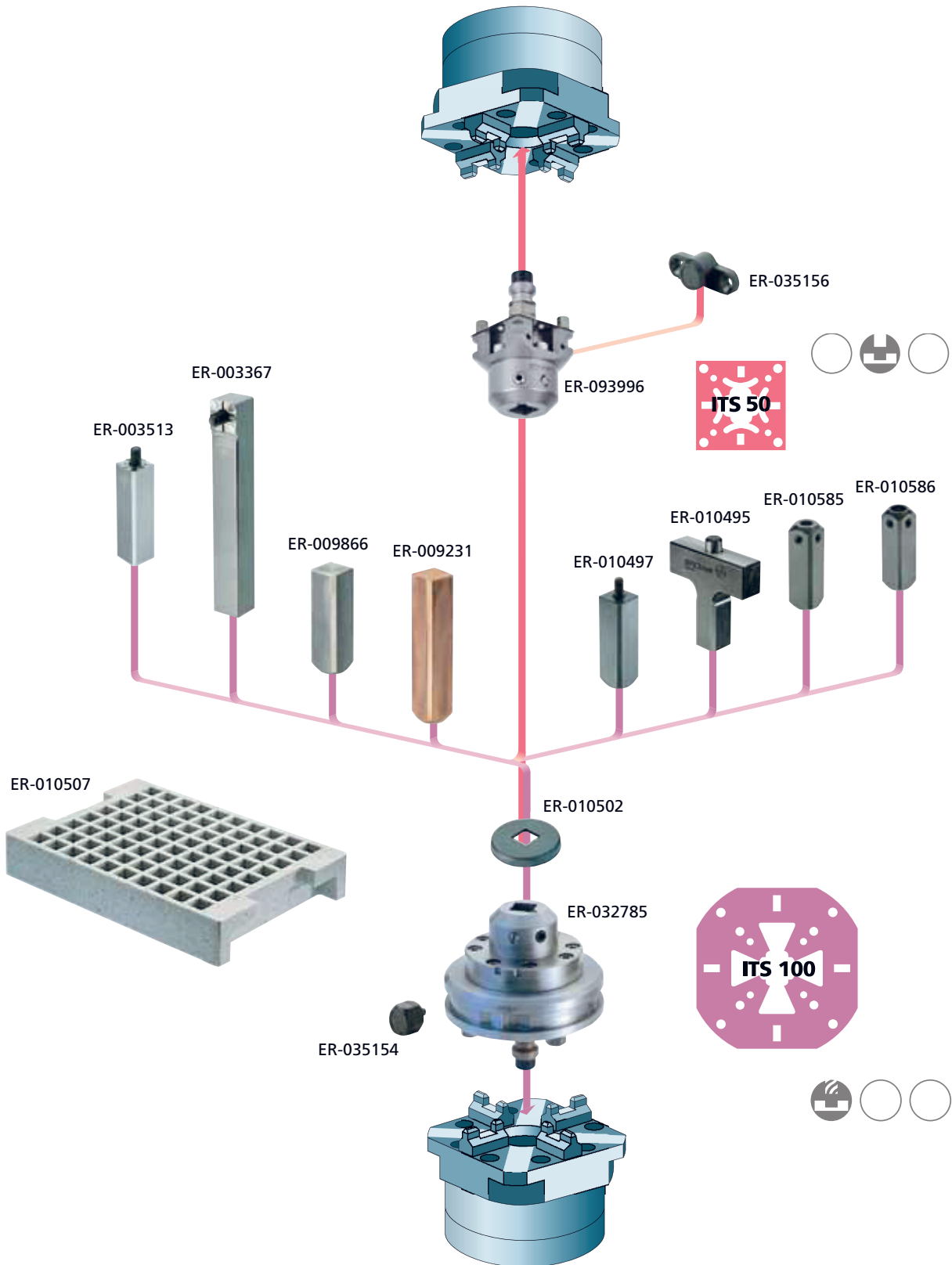

ITS

EROWA ITS Square Electrode System

Square Electrode Clamping System 15

ER-093996 Square 15 holder C
1 pieces

ER-093997 Square 15 holder C
12 pieces



Version ITS system size 50.
Application EDM/WEDM.

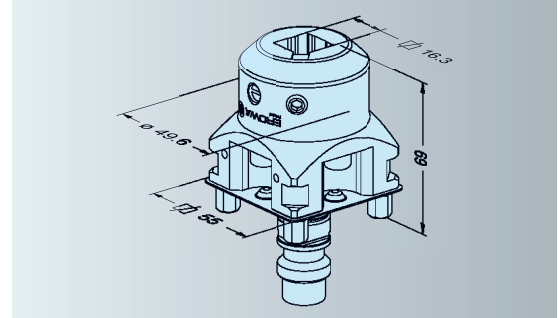

ER-032785 Square 15 holder EWIS™
for ITS 100



Version ITS system size 100
Application EDM and chip-cutting processes.

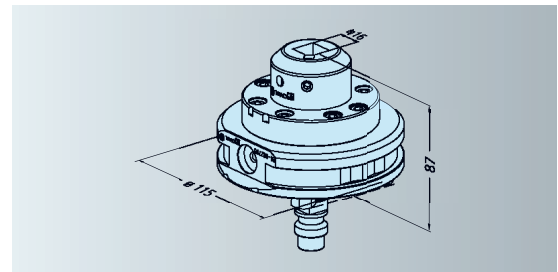

ER-007870 Square 15 holder front part



Version Only clamping part of the holder.
Application For the construction on multiple fixtures.

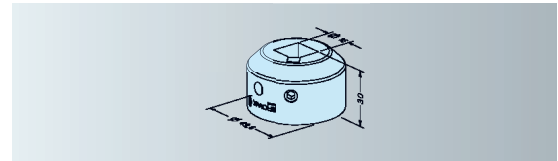

ER-015627 Square 15 holder on adapter ø 85



Version Clamping part fitted to flange, positioned with rods.
Application For the construction on multiple fixtures.
Mounting From above through the flange into the base.

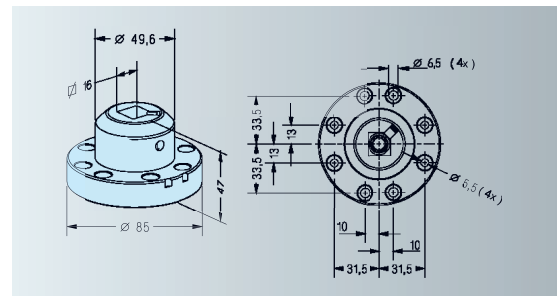

**ER-009231 Square 15 electrode blank
40 pieces**



Version Set of 40 blanks. EDM copper, drawn profile.
 Application Blank for electrodes of up to 15 mm square.

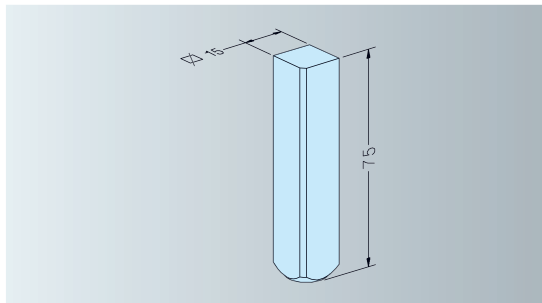

**ER-009866 Square 15 electrode shaft
40 pieces**



Version Set of 40 shafts, drawn steel.
 Application To solder or bond to copper or graphite electrode blanks.

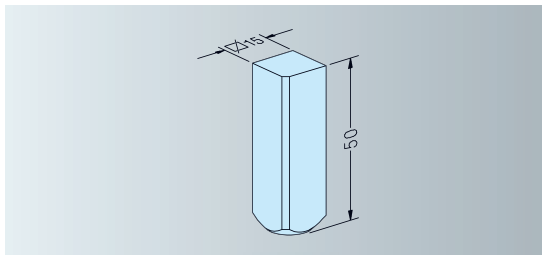

**ER-010497 Square 15 electrode shaft M5
10 pieces**



Version Set of 10 blanks, hardened, ground, including M5 bolts.
 Application To screw on to electrode blanks.

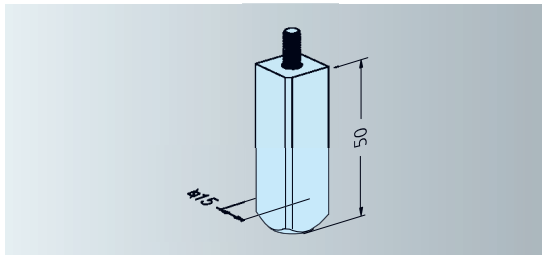

ER-010585 Square 15 blank holder \varnothing 8mm



Version Steel, hardened, ground.
 Application To clamp round parts of \varnothing 8 mm.

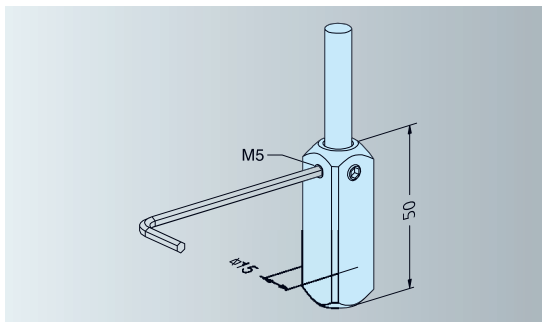

EROWA ITS Square Electrode System

Square Electrode Clamping System 15 and System Plus

ER-010586 Square 15 blank holder \varnothing 6 mm



Version Steel, hardened, ground.
Application To clamp round parts of \varnothing 6 mm.

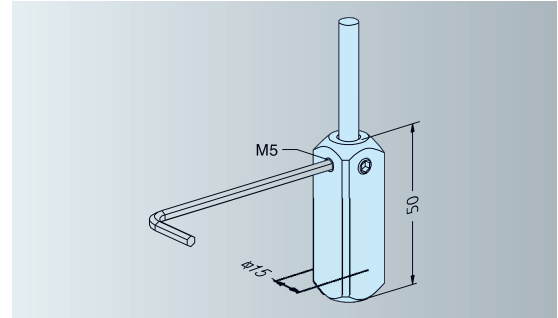

ER-003467 Holder straight 15 x 15 x 37 mm

ER-003513 Holder straight 15 x 15 x 57 mm



Version Steel, hardened, ground. Centering profile 15 mm.
Holder incl. bolt.
Application For electrodes of copper or graphite.
Fitting according to supplied instructions.

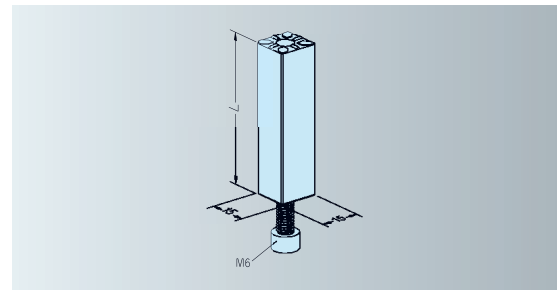

ER-003470 Holder straight 15 x 15 x 50 mm

ER-003367 Angle holder 15 x 15 x 100 mm



Version Steel, hardened, ground. Centering profile 15 mm.
Holder incl. bolt.
Application For electrodes of copper or graphite.
Fitting according to supplied instructions.

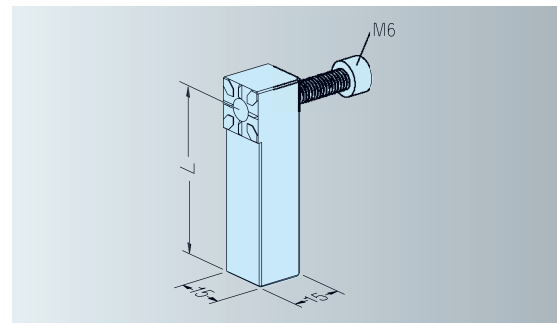

ER-003422 Prism die size 15



Version Steel, hardened, ground. Embossed profile 15 mm.
Application Embossing of centering prisms in blanks.

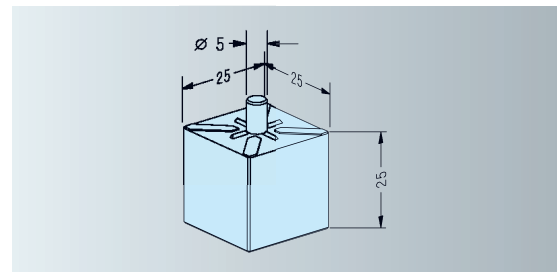

**ER-010507 Square 15 electrode stand
 10 pieces**

Version Set of 10 stands, styrene.
 Application Storage and transport of blanks and electrodes.

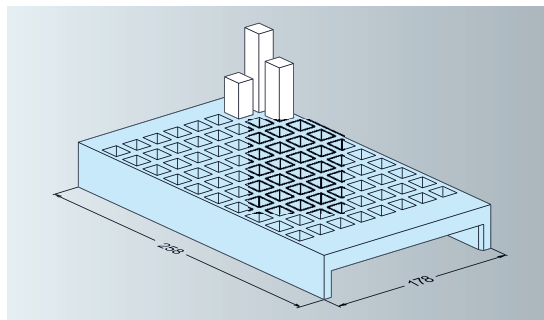

**ER-010502 Square 15 chip guard
 10 pieces**

Version Set of 10 guards, oil-resistant rubber.
 Application Protection against chips during electrode manufacturing.

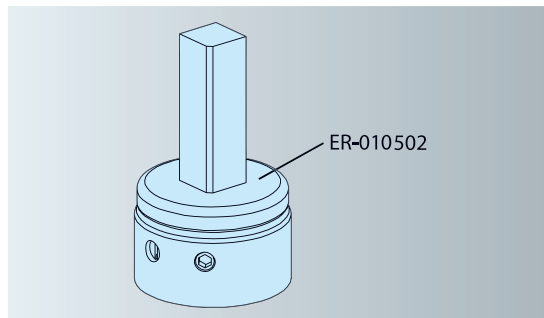

ER-010495 Square 15 alignment rail

Version Steel, hardened, ground.
 Application Testing of concentricity and angular accuracy of holder to ITS system.

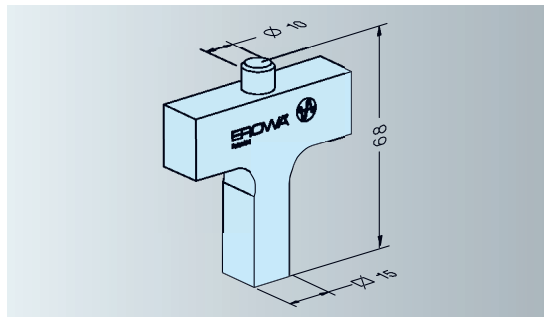

EROWA ITS Square Electrode System

Square Electrode Clamping System 25

ER-093992 Square 25 holder C
1 pieces

ER-093993 Square 25 holder C
12 pieces



Version ITS system size 50.
Application EDM/WEDM.

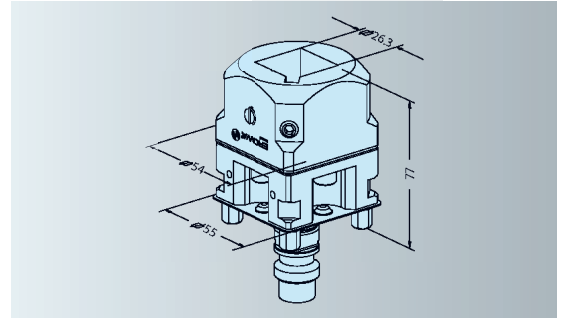

ER-032810 Square 25 holder EWIS™
for ITS 100



Version ITS system size 100.
Application EDM and chip-cutting processes.

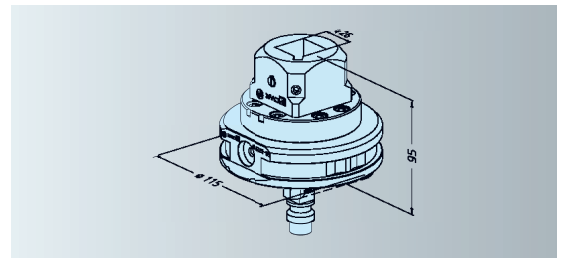

ER-010622 Square 25 holder front part



Version Only clamping part of the holder.
Application For the construction on multiple fixtures.

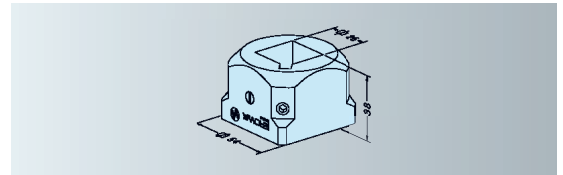

ER-015629 Square 25 holder on adapter ø 85



Version Clamping part fitted to flange, fixed with rods.
Application For the construction on multiple fixtures.
Mounting From above through the flange into the base.

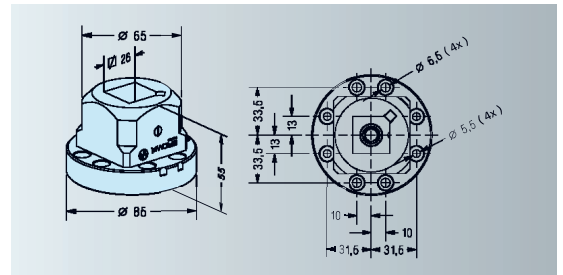

EROWA ITS Square Electrode System

Square Electrode Clamping System 25 and System Plus

ER-009209 Square 25 electrode blank 24 pieces



Version Set of 24 blanks. EDM copper, drawn profile.
Application Blank for electrodes of up to 25 mm edge square.

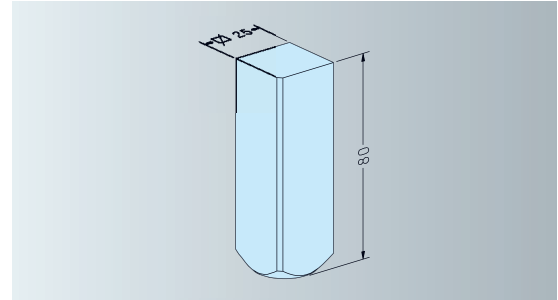

ER-010491 Square 25 electrode shaft 24 pieces



Version Set of 24 shafts, soft steel, drawn profile.
Application To solder or bond to blanks of up to 40 mm square.

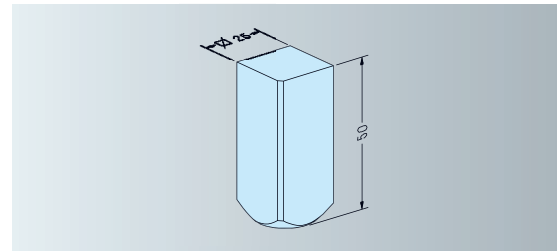

ER-003405 Holder straight 25 x 25 x 40 mm

ER-003439 Holder straight 25 x 25 x 65 mm



Version Steel, hardened, ground. Centering profile 25 mm. Holder incl. bolt.
Application For electrodes of copper or graphite. Fitting according to supplied instructions.

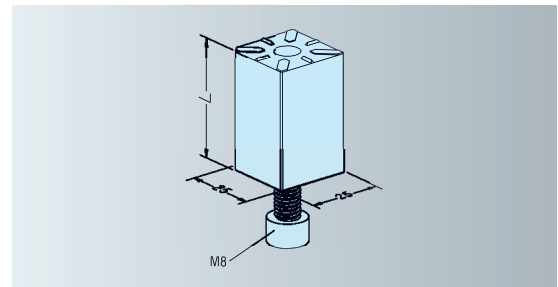

ER-003393 Angle holder 25 x 25 x 90 mm



Version Steel, hardened, ground. Centering profile 25 mm. Holder incl. bolt.
Application For electrodes of copper or graphite. Fit according to supplied instructions.

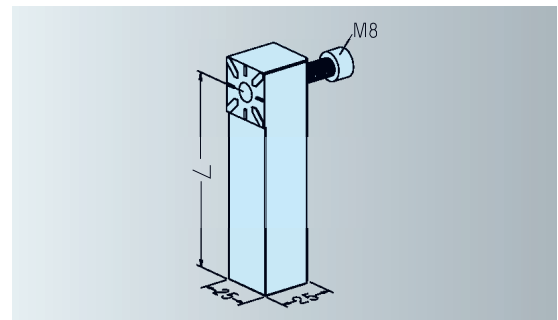

ER-003489 Prism die size 25

Version Steel, hardened, ground. Embossed profile 25 mm.
Application Embossing of centering prisms in blanks.

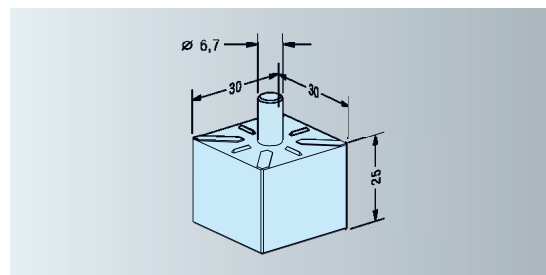
**ER-010592 Square 25 alignment rail**

Version Steel, hardened, ground.
Application Testing of concentricity and angular accuracy of the holder to the ITS system.

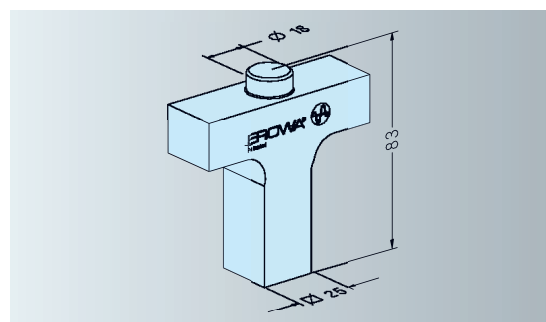
**ER-010505 Square 25 chip guard
10 pieces**

Version Set of 10 guards, oil-resistant rubber.
Application Protection against chips during electrode manufacturing.

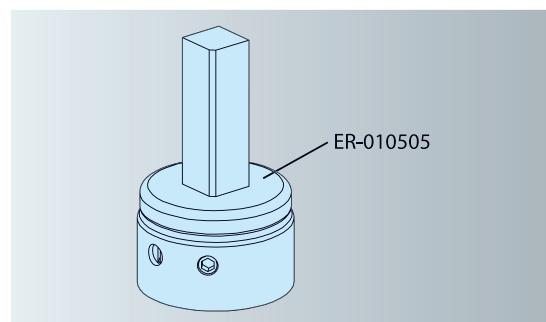
**ER-010511 Square 25 electrode stand
10 pieces**

Version Set of 10 styrene stands.
Application Storage and transporting of blanks and electrodes.

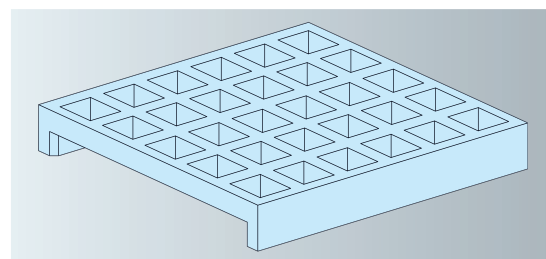

EROWA ITS Square Electrode System

ITS Square 25 Element Set

This will provide you with the complete basic equipment to work with EROWA's square 25 system. Additional material, consumables in particular, can be ordered according to requirements.



ER-103678 Square 25 Electrode Set

This material is packed into one solid plastic box.

Order number	Description	Units per set	Units supplied by order number
ER-032810	Square 25 holder EWIS, for chip-cutting processes	1	1
ER-006641	Socket wrench SW4 for square holder	3	1
ER-009209	Square 25 electrode blank, holder	24	24
ER-010491	Square 25 electrode shaft, steel	24	24
ER-010505	Square 25 electrode chip guard	10	10
ER-010511	Square 25 electrode stand, styrene	2	10
ER-010592	Square 25 checking pin	1	1
ER-093992	Square 25 electrode holder 50 C, for use on EDM centers	2	1



EROWA ITS Special Electrode Holders

The components

These holders support the manufacturing of special electrodes. Thanks to their adjustable angular and axial positions, existing electrodes can be integrated into the system. One of each of these holders should be kept ready for use in every workshop.

SAVE TIME

Machine changes and in-process-control without loss of time thanks to fixed reference position.

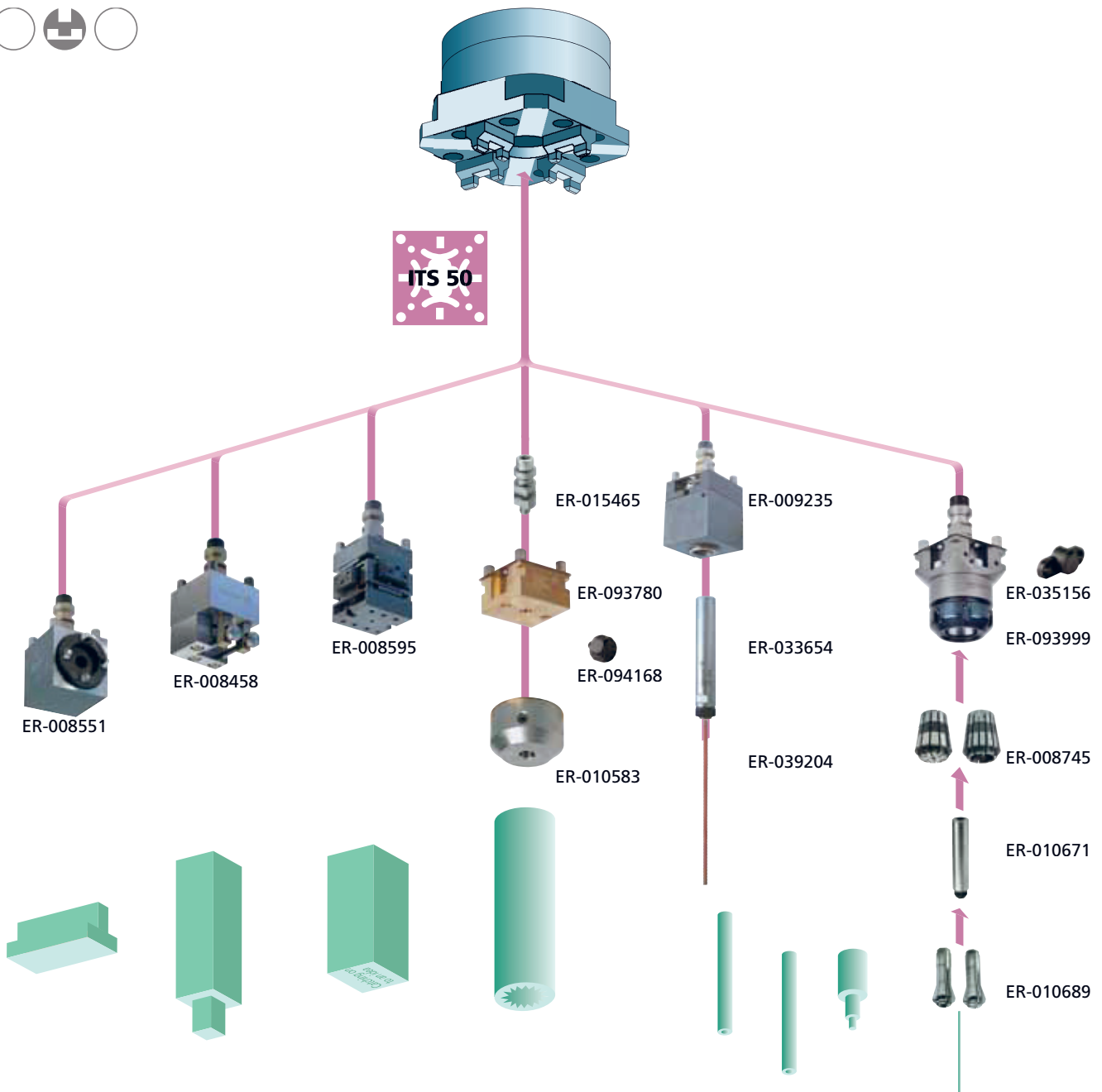

EROWA

ITS Special Electrode Holders

ER-093999 Collet chuck holder 50 C

Version System size 50,
incl. wrench.

Application For round material up to \varnothing 20 mm.

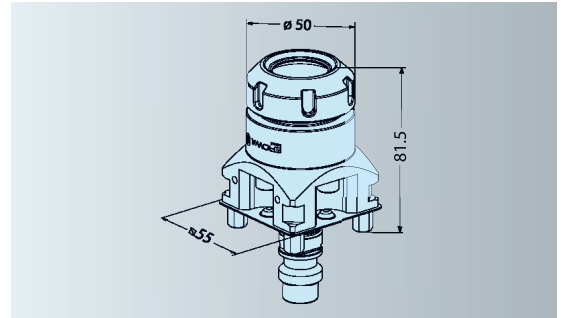
**ER-032815 Collet chuck holder 100**

Version System size 100

Application For round material up to \varnothing 20 mm.

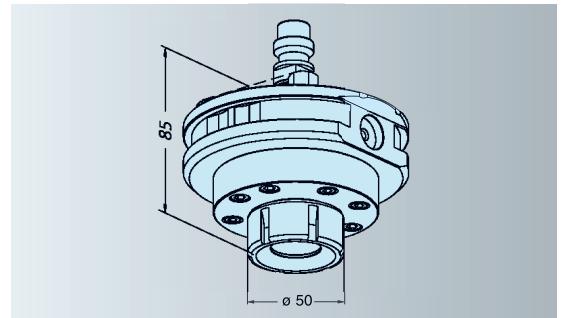
**ER-008745 Set of collet chucks ETS 32 \varnothing 2.5 - 20 mm**

Version 19 collet chucks from \varnothing 2.5 mm to \varnothing 20 mm.

Application For round material up to \varnothing 20 mm.

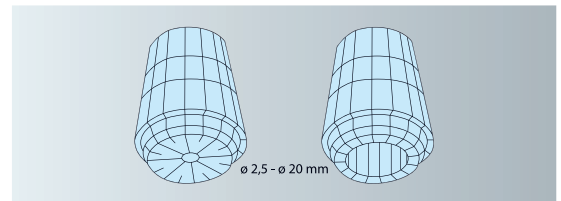

EROWA ITS Special Electrode Holders

ER-006700	Collet chuck \varnothing 2.5 mm ETS 32
ER-006701	Collet chuck \varnothing 3 mm ETS 32
ER-006702	Collet chuck \varnothing 4 mm ETS 32
ER-006703	Collet chuck \varnothing 5 mm ETS 32
ER-006704	Collet chuck \varnothing 6 mm ETS 32
ER-006705	Collet chuck \varnothing 7 mm ETS 32
ER-006706	Collet chuck \varnothing 8 mm ETS 32
ER-006707	Collet chuck \varnothing 9 mm ETS 32
ER-006708	Collet chuck \varnothing 10 mm ETS 32
ER-006709	Collet chuck \varnothing 11 mm ETS 32
ER-006710	Collet chuck \varnothing 12 mm ETS 32
ER-006711	Collet chuck \varnothing 13 mm ETS 32
ER-006712	Collet chuck \varnothing 14 mm ETS 32
ER-006713	Collet chuck \varnothing 15 mm ETS 32
ER-006714	Collet chuck \varnothing 16 mm ETS 32
ER-006715	Collet chuck \varnothing 17 mm ETS 32
ER-006716	Collet chuck \varnothing 18 mm ETS 32
ER-006717	Collet chuck \varnothing 19 mm ETS 32
ER-006718	Collet chuck \varnothing 20 mm ETS 32



Version Delivered separately, clamping range per collet chuck:
 \varnothing 2.5 mm = 0.5 mm
 \varnothing 3-20 mm = 1 mm

Application Round material from \varnothing 2 mm to \varnothing 20 mm.

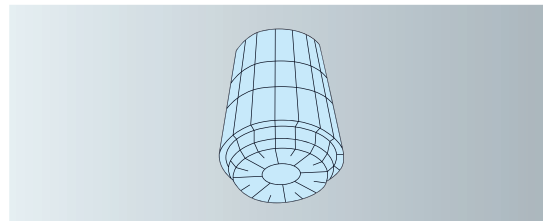

ER-010671 Mini collet chucks holder \varnothing 20



Version Steel ground \varnothing 20 mm.

Application In \varnothing 20 mm adapter or in \varnothing 20 mm collet chuck for mini collet chucks of \varnothing 0.2 mm to \varnothing 2 mm.

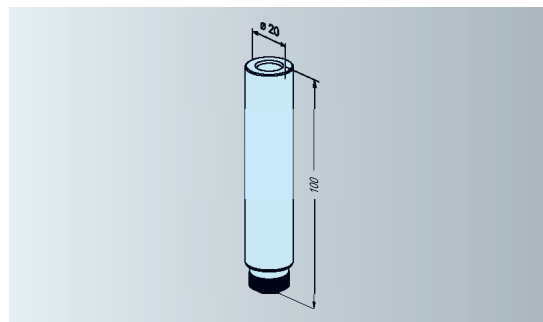

ER-010689 Set of mini collet chucks



Version Set of 19 collet chucks \varnothing 0.2 mm to \varnothing 2.0 mm, steel ground, with brass seal for appropriate diameter.

Application Clamping of small electrode tubes \varnothing 0.2 mm to \varnothing 20 mm.

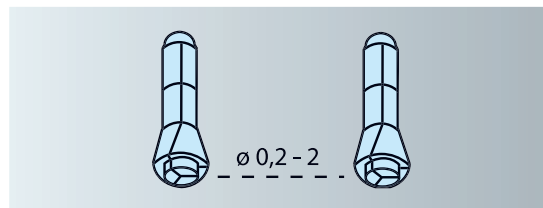

ER-002403	Mini collet chuck \varnothing 0.2 mm
ER-002404	Mini collet chuck \varnothing 0.3 mm
ER-002405	Mini collet chuck \varnothing 0.4 mm
ER-002406	Mini collet chuck \varnothing 0.5 mm
ER-002407	Mini collet chuck \varnothing 0.6 mm
ER-002408	Mini collet chuck \varnothing 0.7 mm
ER-002409	Mini collet chuck \varnothing 0.8 mm
ER-002410	Mini collet chuck \varnothing 0.9 mm
ER-002411	Mini collet chuck \varnothing 1.0 mm
ER-002412	Mini collet chuck \varnothing 1.1 mm
ER-002413	Mini collet chuck \varnothing 1.2 mm
ER-002414	Mini collet chuck \varnothing 1.3 mm
ER-002415	Mini collet chuck \varnothing 1.4 mm
ER-002416	Mini collet chuck \varnothing 1.5 mm
ER-002417	Mini collet chuck \varnothing 1.6 mm
ER-002418	Mini collet chuck \varnothing 1.7 mm
ER-002419	Mini collet chuck \varnothing 1.8 mm
ER-002420	Mini collet chuck \varnothing 1.9 mm
ER-002421	Mini collet chuck \varnothing 2.0 mm

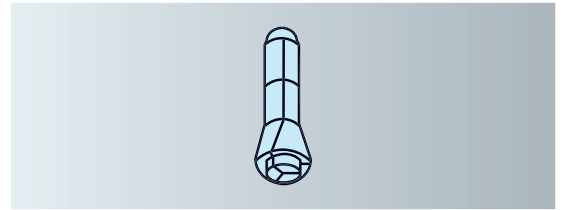

Version Steel, ground, with brass seal for appropriate diameter.
 Application Clamping of small electrode tubes.

EROWA Collet Chuck Tooling System

For workpieces in many shapes, including workpieces that are not rotationally symmetrical, a collet chuck is the optimal holding device. EROWA CTS combines the features of the tooling system with the well-known advantages of collet chucks.

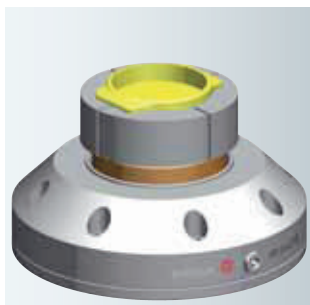
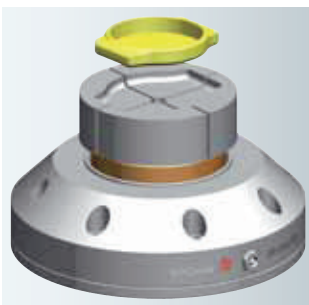

Ask your specialist EROWA dealer for more information about the entire EROWA CTS range.

EROWA

ITS Special Electrode Holders

ER-008595 Zekant



Version Electrode holder with cross slide (2 mm travel) and pendulum movement ($\pm 4^\circ$).

Application Clamping and alignment of electrodes.
Not suitable for chip-machining.

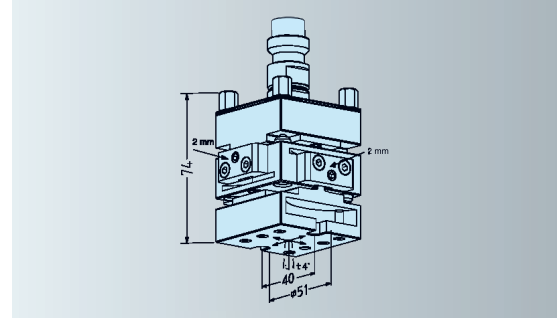

ER-008458 V-block holder stainless

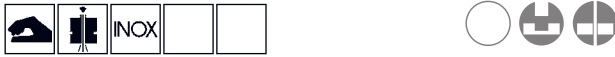

Version Prism ground bearing surfaces 10 mm ± 0.005 mm from the center.

Application Clamping from outside, precision machined electrodes or small workpieces.

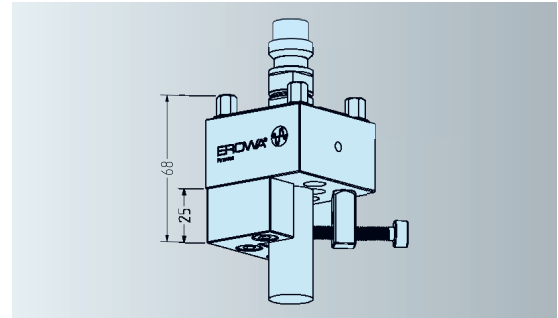

ER-008551 Horizontal holder



Version Hardened and ground 90° angle and centering accuracy 0.005 mm.

Application Clamping of electrode holders in horizontal position, may not be used for chip-machining.

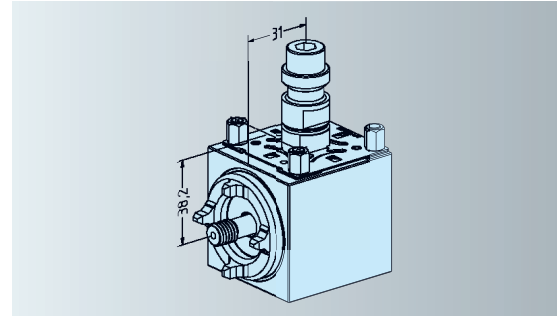

ER-010583 Blank holder \varnothing 10 mm

ER-010581 Blank holder \varnothing 12 mm

ER-010577 Blank holder \varnothing 20 mm



Version Steel, hardened, ground bore.

Application Fit to Uniplate C ER-093780 for clamping of precision copper tubes or bars.

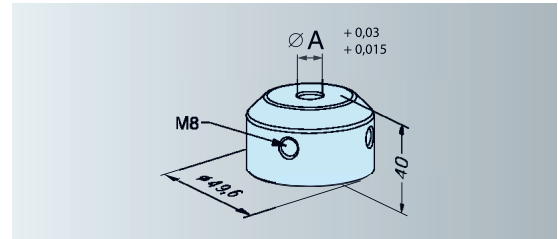

ER-009235 Adapter \varnothing 20 mm

Version Hydraulic holding of \varnothing 20 mm shafts.
 Application Recommended to hold the 20 mm EROWA thread holder.

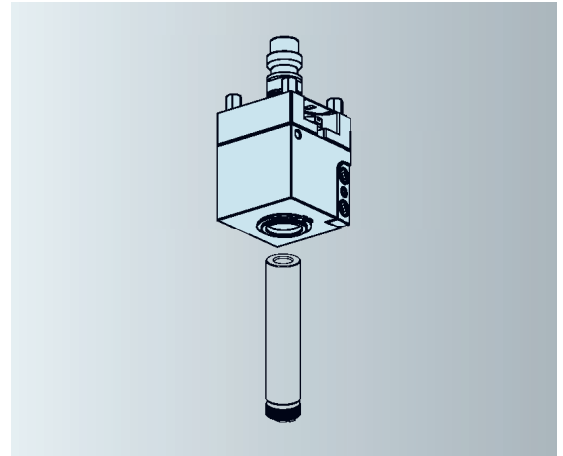

ER-033654 Thread holder M3
 P=0.5mm / \varnothing 2.3 mm / L= 100

ER-033655 Thread holder M4
 P=0.7mm / \varnothing 2.9 mm / L= 100

ER-033656 Thread holder M5
 P=0.8mm / \varnothing 3.8 mm / L= 120

ER-033657 Thread holder M6
 P=1mm / \varnothing 4.5 mm / L= 120



Version Ground 20 mm shaft.
 Application Defined positioning of threaded EROWA electrodes.
 Note Systems for M3, M4, M5 and M6.

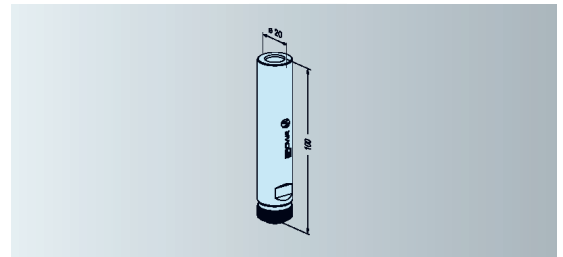

ER-033204 Threaded electrode M3 / L= 80

ER-033205 Threaded electrode M4 / L= 80

ER-033206 Threaded electrode M5 / L= 120

ER-033207 Threaded electrode M6 / L= 120



Version EDM copper with precision thread.
 Application For EDM-ing threads with EROWA Thread holder System.
 Note Sizes available for: M3, M4, M5 and M6.

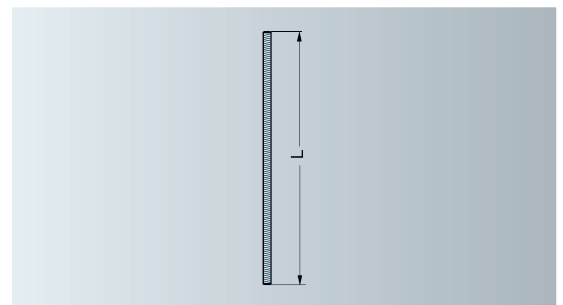

EROWA

Measuring and Checking Elements

The components

Trusting is good - checking is better. These specially designed elements will make it easier for you to check your production equipment. These elements are for use both in chip-cutting applications and in EDM sinking and WEDM.

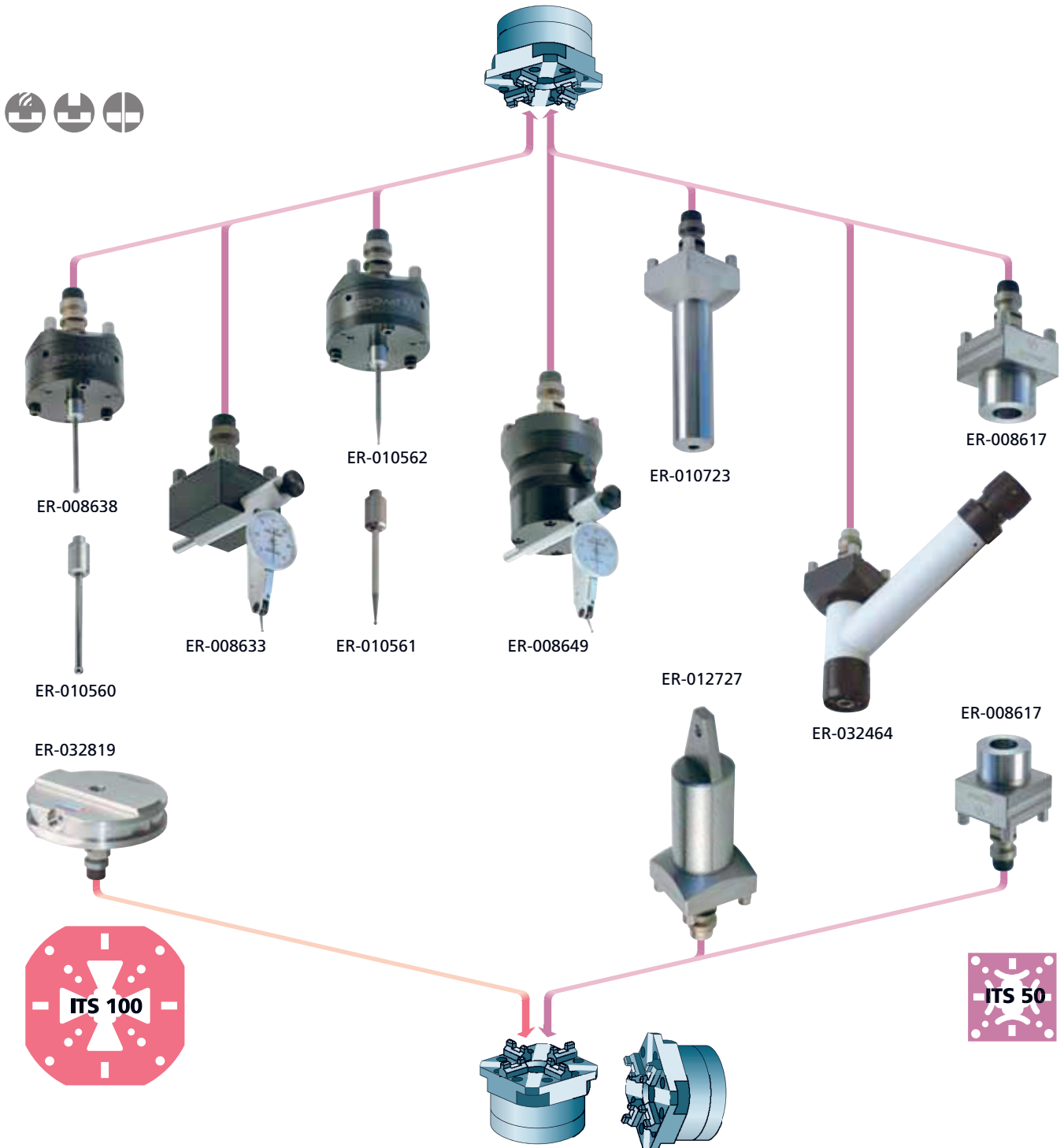

EROWA

Measuring and Checking Elements

ER-008638 Sensor with ball \varnothing 5 mm
ER-010562 Sensor with ball \varnothing 2 mm

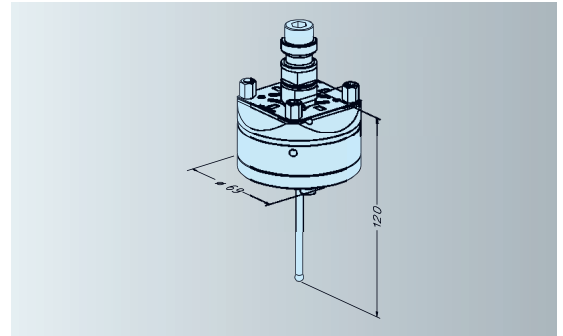

Version Holder with spring-loaded sensing pin and tungsten carbide ball. Overrun protection: X, Y, Z 1 mm. Repetition accuracy: X, Z, Y 0.002 mm.

Application Automatic measurement of workpieces in CNC EDM- sinking centers.

ER-010560 Replacement sensor pin \varnothing 5 mm
ER-010561 Replacement sensor pin \varnothing 2 mm

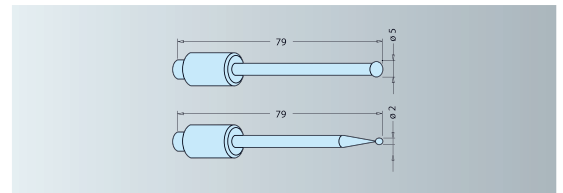

Version Tungsten carbide, incl. adapter part, without spacer washer

Application Replacement of pins in sensors ER-008638 and ER-010562. Attention: spacer washer is matched to the respective sensor.

ER-010723 Checking pin 50

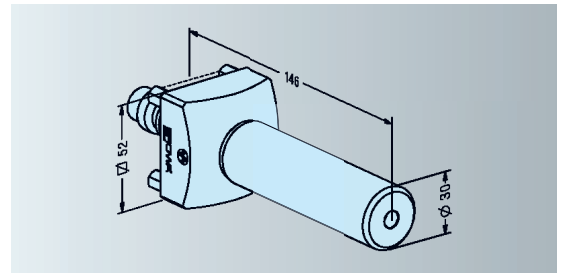

Version Hardened, ground.

Application Alignment of radial, axial and angular position of ITS chucks.

ER-008617 Gauging pin

Version Hardened, ground.

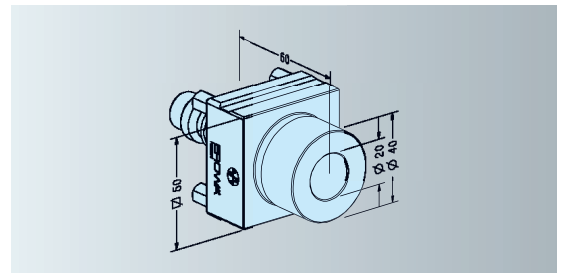
Application Alignment of ITS chucks in radial, axial and angular position.



EROWA

Measuring and Checking Elements

ER-012727 Reference pin UnoSet



Version Hardened, ground, borehole \varnothing 8 mm.
 Application To determine reference measurements on horizontal chucks.

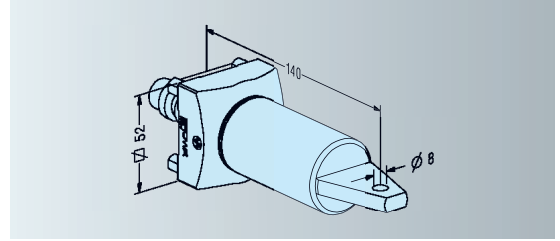

ER-008633 Fixed centering device



Version Holder with sliding part and metric dial gauge mm.
 Scale graduation: 0.01 mm.
 Application Concentricity measurement of workpieces on machines with C-axis or rotating spindle.

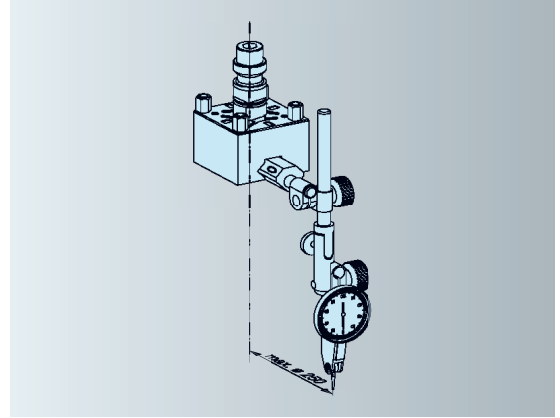

ER-008649 Rotatable centering device complete



Version Holder with rotating and sliding part, including metric dial gauge mm. Scale graduation: 0.01 mm.
 Application Concentricity measurement of workpieces on machines without rotating axis.

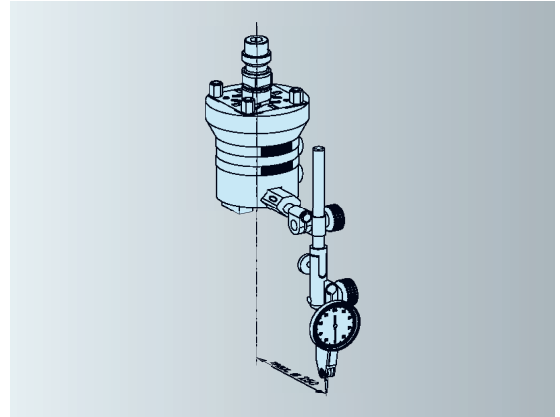

ER-032819 Alignment pallet \varnothing 115



Version Pallet \varnothing 115 mm, alignment length 110 mm, center borehole \varnothing 12 mm.
 Application Alignment of radial, axial and angular position of ITS chucks, PowerChuck P and PC 210 Combi chucks.

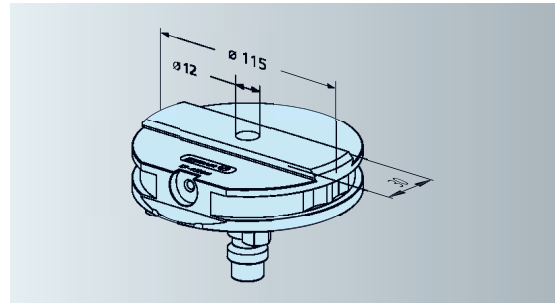

ER-032464 Microscope with pointed checking pin

Version	Amplification factor: 40x Illumination: 5 V, Transformer: 100-240 V.
Application	Determination of dimensions for complicated contours. The checking pin with tip serves for adjustment of the optical system.

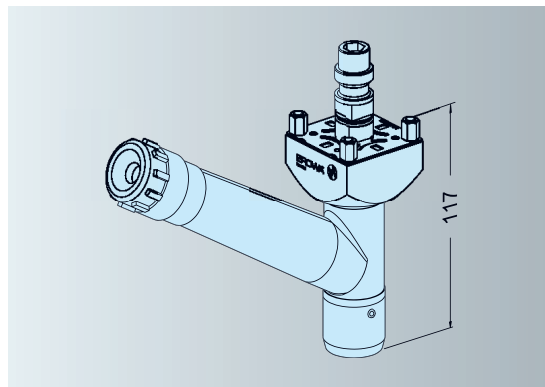
**ER-001565 Dial gauge \varnothing 38, 0.002mm**

Version	Measuring range +/- 0.2 mm Graduation 0.002 mm.
Application	On PreSet setup and pre-setting cells, and on ITS centering devices.

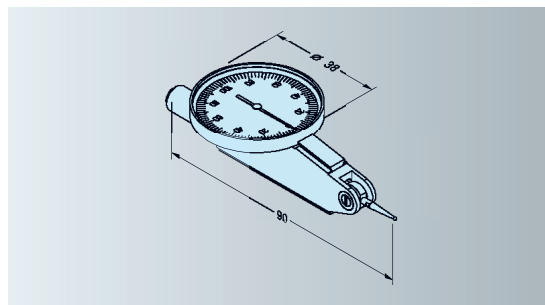

EROWA ITS Element Set

My first EROWA

We have compiled practical sets for newcomers to the modern ITS Integrated Tooling System. Additional material, consumables in particular, can be ordered according to requirements.



Starter set for newcomers, with existing ITS chuck on the EDM quill.

ER-015465

ER-010583

ER-010581

ER-010577

ER-038824

ER-010723

ER-010441

ER-010438

ER-103692

ER-093780

ER-093774

ER-093758

ER-093765

ER-010906

ER-103687

ER-103679 My first EROWA

This material is packed into one solid plastic box.

Order number	Description	Units per set	Units supplied by order number
ER-093758	Uniblank C EWIS	3	12
ER-093765	Prisround C EWIS	3	12
ER-093774	Uniholder C EWIS	3	12
ER-093780	Uniplate C EWIS	3	12
ER-010438	Setscrew M8 x 16 for Prisround	6	25
ER-010441	Setscrew M8 x 16 for Uniholder	6	25
ER-010577	Blank holder \varnothing 20 mm	1	1
ER-010581	Blank holder \varnothing 12 mm	1	1
ER-010583	Blank holder \varnothing 10 mm	1	1
ER-103692	Hexagon socket bolt M6 x 20 for Uniplate C	6	12
ER-010723	Checking pin	1	1
ER-010906	Toolkit ITS	1	1
ER-038824	QuickChuck 100 P with base plate	1	1
ER-015465	Chucking spigot F/A EDM	5	20
ER-103687	Set of SW5 hex keys for ITS C	1	1



EROWA ITS Element Set EDM Set

We have compiled practical sets for newcomers to the modern ITS Integrated Tooling System. Additional material, in particular consumables, can be ordered according to requirements.

User set for manual or CNC EDM centers with ITS quill chuck. The supplied chuck has been designed for manual electrode manufacturing.



ER-103680 QuickChuck 100 EDM Set

This material is packed into two solid plastic boxes.

Order number	Description	Units per set	Units supplied by order number
ER-000974	M10 x 20 hex socket head bolt	1	1
ER-001483	Key for collet holder 50	1	1
ER-006702	Collet \varnothing 4mm	1	1
ER-006704	Collet \varnothing 6 mm	1	1
ER-006706	Collet \varnothing 8 mm	1	1
ER-006708	Collet \varnothing 10 mm	1	1
ER-006710	Collet \varnothing 12 mm	1	1
ER-006718	Collet \varnothing 20 mm	1	1
ER-008458	Prism holder, stainless	1	1
ER-093999	Collet holder 50 C	1	1
ER-103687	Set of SW5 hex keys for ITS C	1	1

ER-103680 QuickChuck 100 EDM Set

This material is packed into two solid plastic boxes.

Order number	Description	Units per set	Units supplied by order number
ER-094180	Centering plate 50 C with washer	20	50
ER-011599	Centering plate 100 M5 with washer	5	10
ER-093765	Prisround C EWIS	6	12
ER-093774	Uniholder C EWIS	6	12
ER-093780	Uniplate C EWIS	6	12
ER-010438	Setscrew M8 x 16 for Prisround	12	25
ER-010441	Setscrew M8 x 16 for Uniholder	12	25
ER-010514	Spacer plate 0,5 mm	50	50
ER-010518	Spacer plate 1 mm	50	50
ER-010521	Spacer plate 2 mm	50	50
ER-010523	Spacer plate 3 mm	50	50
ER-010525	Spacer plate 4 mm	50	50
ER-010526	Spacer plate 5 mm	50	50
ER-103692	Hexagon socket bolt for Uniplate C	12	12
ER-010694	Sealing washers	12	24
ER-010710	Drilling template for borehole patterns, centering plates 50 and 100	1	1
ER-010723	Checking pin	1	1
ER-010753	Support feet M5	100	100
ER-010906	Toolkit ITS	1	1
ER-038824	QuickChuck 100 P with base plate	1	1
ER-015465	Chucking spigot F/A EDM	10	20
007752	M8 support foot	20	–
000999	M5 x 8 socket head bolt	20	–

EROWA ITS Element Set

EDM Standard Set

We have compiled practical sets for newcomers to the modern ITS Integrated Tooling System. Additional material, in particular consumables, can be ordered according to requirements.

User set for manual or CNC centers. Containing, among other things, 50 electrode holders and a chuck.

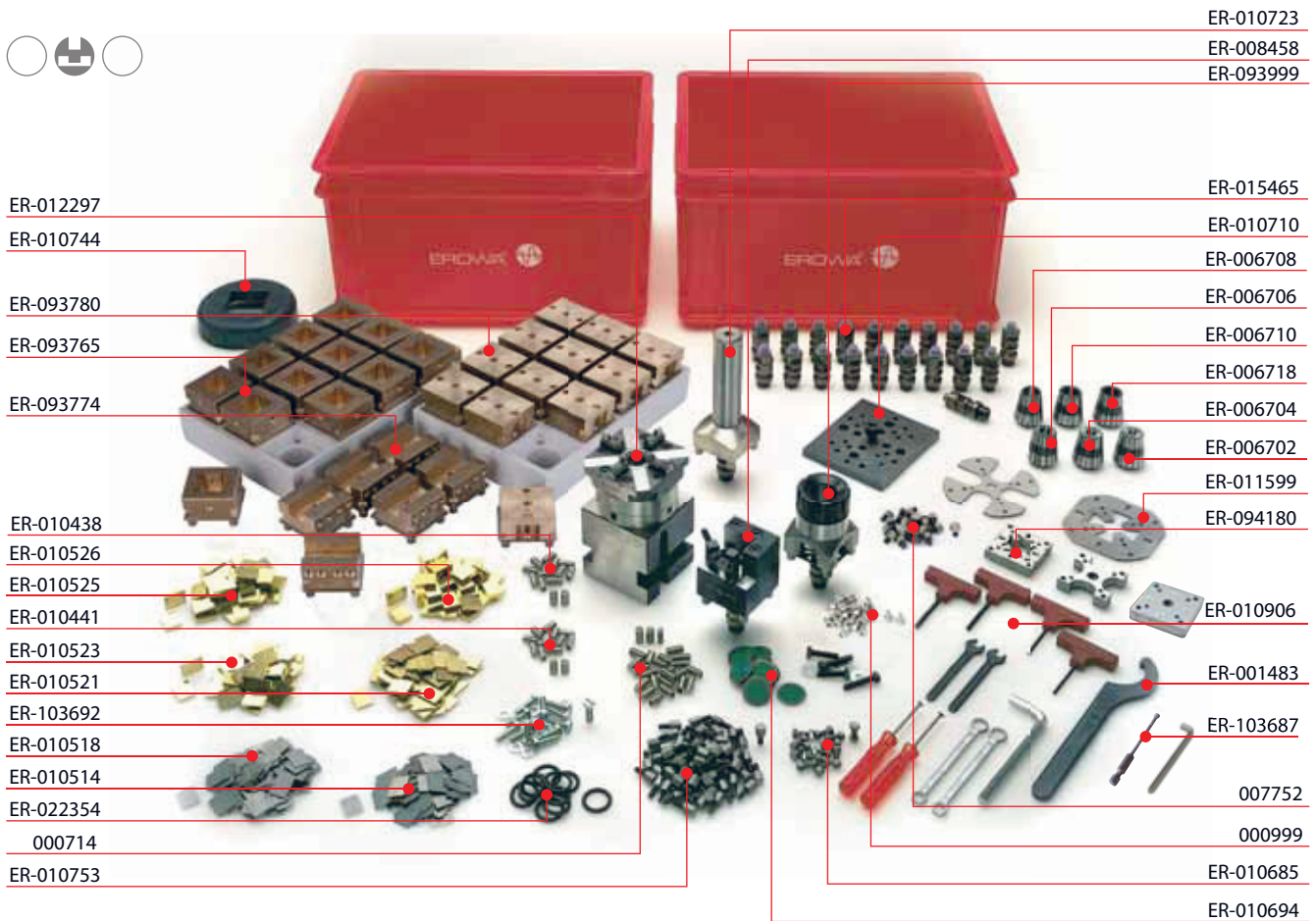

ER-103681 EDM Standard Set

This material is packed into two solid plastic boxes.

Order number	Description	Units per set	Units supplied by order number
000714	Setscrew M8 x 16	25	1
ER-001483	Key for collet holder 50	1	1
ER-006702	Collet \varnothing 4 mm	1	1
ER-006704	Collet \varnothing 6 mm	1	1
ER-006706	Collet \varnothing 8 mm	1	1
ER-006708	Collet \varnothing 10 mm	1	1
ER-006710	Collet \varnothing 12 mm	1	1
ER-006718	Collet \varnothing 20 mm	1	1
ER-103687	Set of SW5 hex keys for ITS C	1	1

ER-103681 EDM Standard Set

This material is packed into two solid plastic boxes.

Order number	Description	Units per set	Units supplied by order number
ER-012297	Rapid-action chuck, manual, on block	1	1
ER-008458	Prism holder	1	1
ER-093999	Collet holder 50 C	1	1
ER-094180	Centering plate 50 C with washer	20	50
ER-011599	Centering plate 100 M8 with washer	5	10
ER-093765	Prisround C EWIS	12	12
ER-093774	Uniholder C EWIS	6	12
ER-093780	Uniplate C EWIS	12	12
ER-010438	Setscrew M8 x 16 für Prisround	25	25
ER-010441	Setscrew M8 x 16 for Uniholder	12	25
ER-010514	Spacer plate 0,5 mm	100	50
ER-010518	Spacer plate 1 mm	100	50
ER-010521	Spacer plate 2 mm	100	50
ER-010523	Spacer plate 3 mm	100	50
ER-010525	Spacer plate 4 mm	100	50
ER-010526	Spacer plate 5 mm	100	50
ER-103692	Hexagon socket bolt for Uniplate C	24	12
ER-010694	Sealing washers	12	24
ER-010710	Drilling template for borehole patterns, centering plates 50 and 100	1	1
ER-010723	Checking pin	1	1
ER-010685	Supports M5, adjustable	12	12
ER-010744	Chip guard for rapid-action chuck	1	1
ER-010753	Supports M5	100	100
ER-010906	Toolkit ITS	1	1
ER-015465	Chuckling spigot F/A EDM	20	20
ER-022354	Seal ring for chucking spigot	10	10
007752	M8 support foot	20	–
000999	M5 x 8 socket head bolt	20	–

