

## EROWA PM Tooling

# Pressing powder systematically

Pressed-powder parts are becoming ever more refined, and the diversity of product shapes is on the increase. Batch sizes are becoming smaller, which means that powder presses must be reset frequently.

EROWA has developed a solution for the minimization of resetting times: Single- or multi-level powder presses are equipped with the suitable PM tooling system. In this way, pressing tools can be exchanged in next to no time and with the highest degree of precision.

The EROWA PM tooling system was developed for use under high pressing forces. Depending on the field of application and on requirements, the optimal tooling system can be chosen.

Crucial advantages of the PM tooling systems:

- Repeatability for the highest precision requirements.
- High degree of stability thanks to patented outside clamping.
- User-friendliness.
- Capable of being automated.

These factors directly aim to increase the productivity and economy of your powder press!

**01** | Upper punch on EROWA PM Tooling pallet: Positioning accuracy < 0.002 mm.

**02** | Die-plate on EROWA PM Tooling pallet: Positioning accuracy < 0.002 mm.

**03** | Lower punch on the EROWA PM Tooling pallet: Positioning accuracy < 0.002 mm.

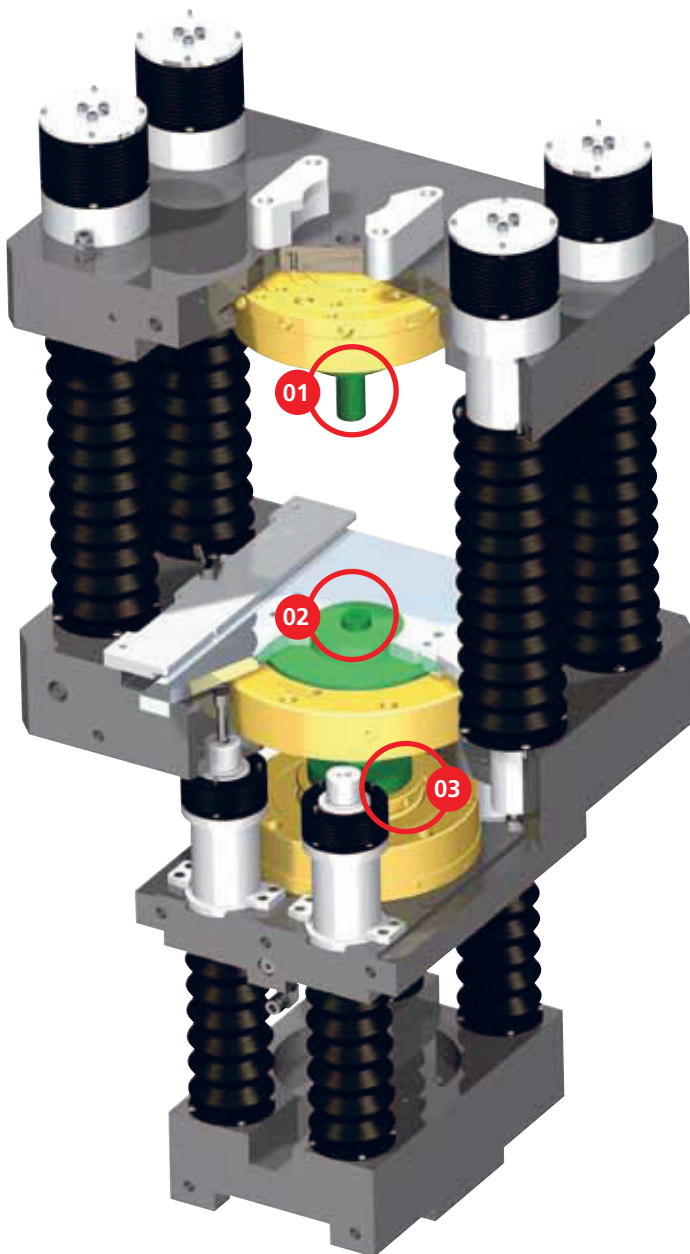

**Applications**



**Handling**

Manual / Loading facility / Robot

**Function**

**Die-plate chuck**

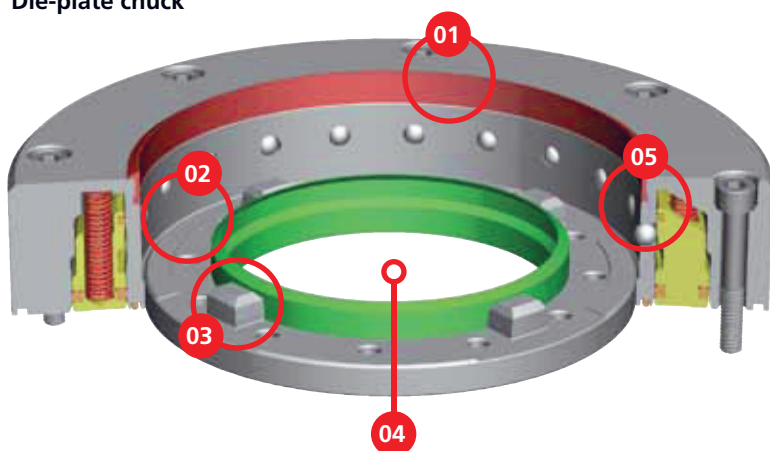

**Punch chuck**

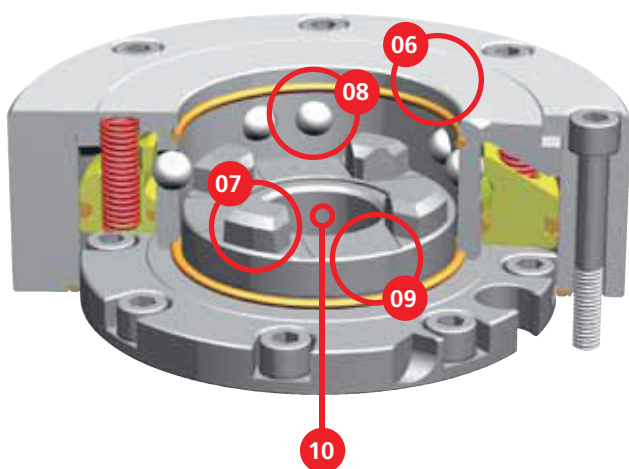

**01** | Fully sealed system; resistant to powder, contamination and liquids.

**02** | Large contact surface for great force absorption.

**03** | Precise «P» centering.

**04** | Wide opening for bottom punch.

**05** | Patented outside clamping.

**06** | Fully sealed system.

**07** | Precise «P» centering.

**08** | Patented outside clamping.

**09** | Large contact surface for great force absorption.

**10** | 25 mm clearance for center pin or second punch.

**Technical data - PM Tooling Precise**

PM Tooling Precise	System size	Max. admissible pressing force
Punch chuck	PM56	500 kN
	PM60	500 kN
	PM85	1000 kN
Die-plate chuck	PM128	1000 kN

# EROWA PM Tooling

## Universal from milling to pressing

With the EROWA PM tooling system, punches and die plates are fitted to pallets and manufactured with datum-point precision. Compatibility with other EROWA tooling systems enables your production machine to be fully automated. Workpieces run through the entire production chain on pallets:

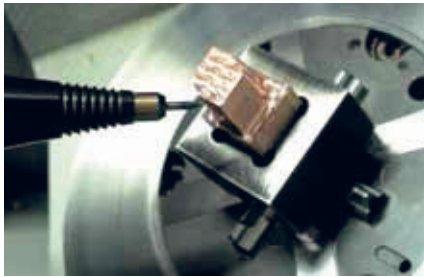

### Milling

Electrodes used to EDM the molds are machined on ITS system holders.

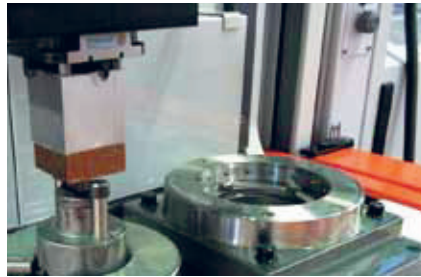

### EDM

Shapes in the surface of the punches are EDMed.



For more information about the whole EROWA PM tooling system range.



### Grinding

Punches may also be machined on cylindrical grinding machines.



### Wire-EDM

The contours are produced on a WEDM center. The reference position is provided by the chuck.

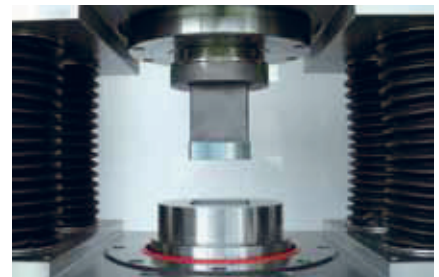

### Powder pressing

Top and bottom punches and the die plate are inserted into the press. The reference positions are provided by the precisely aligned chucks.

### Changing variants in 2 minutes

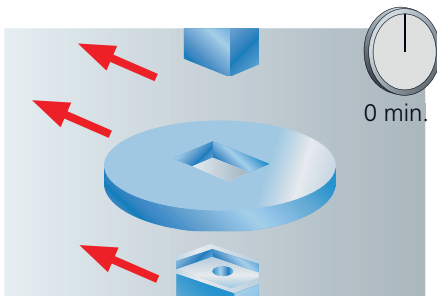

Pneumatically loosen die-plate and both punches.

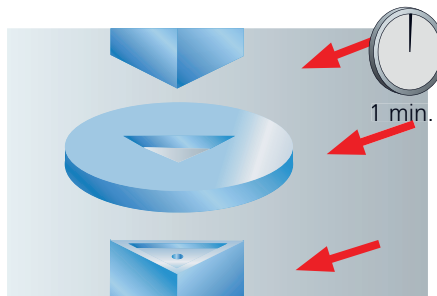



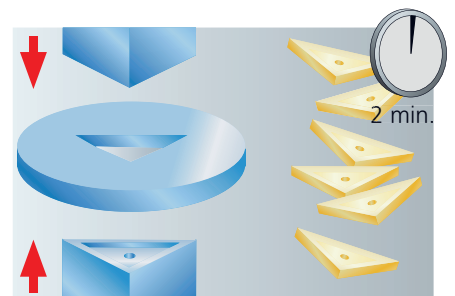













Insert and clamp new die-plate and punches.



Produce new molds.



To make it easier for you to find your way about the fields of application for EROWA products, we use the following symbols in all our documents:

-  1. Manual operation
-  2. Operate with compressed air jet
-  3. Operate with manual valve
-  4. Operate with manual control unit
-  5. Operate with electro-pneumatic control unit
-  6. With central flushing clearance
-  7. Suited for submerged operation
-  8. Corrosion-resistant material
-  9. Suited for automatic operation
-  10. Handling with EROWA Robot gripper S
-  11. Handling with EROWA Robot gripper Combi
-  12. Handling with EROWA Robot gripper C
-  13. Handling with EROWA Robot gripper 72
-  14. Handling with EROWA Robot gripper 115
-  15. Handling with EROWA Robot gripper 148
-  16. Handling with EROWA Robot gripper RN PC 210
-  17. Handling with EROWA Robot gripper RCS

## EROWA PM TOOLING

PM Tooling	Chucks	308
PM Tooling	Pallets	310
PM Tooling	Accessories	311
PM Tooling	Spindle adaptation, chucks	316
PM Tooling	Spindle adaptation, pallets	317



For chip-removing processes



For EDM sinking



For WEDM

# EROWA PM Tooling Precise Chucks

Technical data	PM chucks
Repeatability	0,002 mm
Indexation	4 x 90°
Opening with dry compressed air	min. 6 bar
Clamping	Spring pressure

## ER-047544 Die-plate chuck PM128 II Precise



Version	Steel, hardened. Through borehole $\varnothing$ 86. External seal.
Clamping power	23000 N (reclamped at 6 bar).
Connections	At the rear, with two lines.
Operation	With control unit.
Application	On milling machines and powder presses. To accommodate die-plate pallets PM128 Precise.

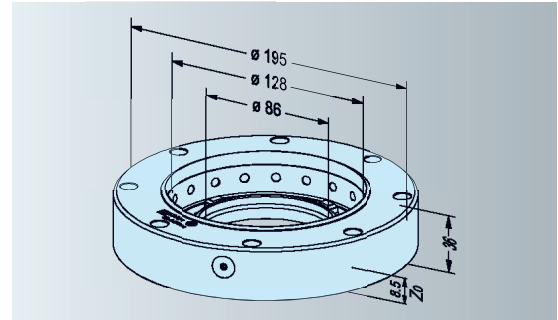

## ER-040697 Chuck PM85 Precise



Version	Steel, hardened, corrosion-resistant. Through borehole $\varnothing$ 25.
Clamping power	9000 N.
Connections	At the rear, with two lines.
Operation	With control unit.
Application	On milling machines, lathes, EDM/WEDM centers and powder presses. To accommodate pallets PM85 Precise.

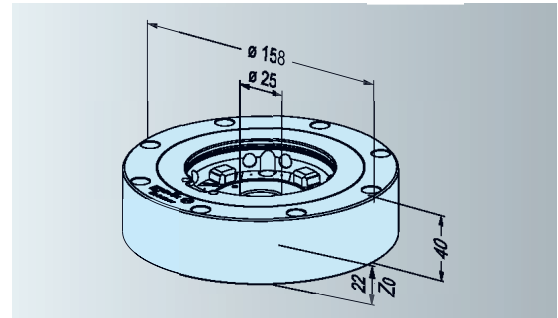

## ER-055370 Chuck PM60 Precise



Version	Steel, hardened, corrosion-resistant. Through borehole $\varnothing$ 25.
Clamping power	6500 N.
Connections	At the rear, with two lines.
Operation	With control unit.
Application	On milling machines, lathes, EDM/WEDM centers and powder presses. To accommodate pallets PM60 Precise.

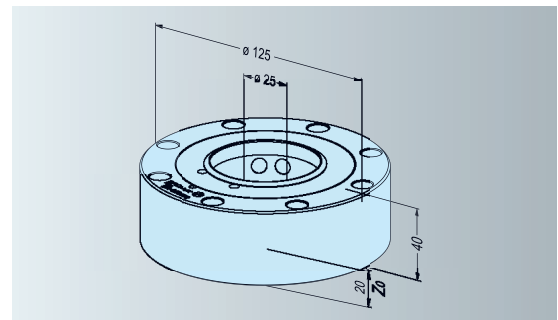

**ER-047566 Die-plate chuck PM128 II Precise with base plate**



Version Steel, hardened, corrosion-resistant.  
Through borehole  $\varnothing 86$ . External seal.

Clamping power 20000 N (reclamped at 6 bar)

Operation Laterally with compressed-air gun or with control unit.

Application On milling machines, lathes, grinding machines and EDM/WEDM centers.  
To accommodate die-plate pallets PM128 Precise and Multi.

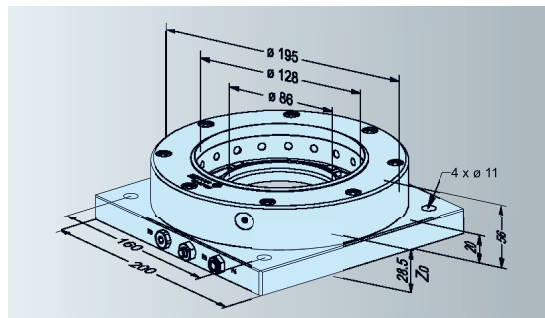

**ER-040696 Chuck PM85 Precise with base plate**



Version Steel, hardened, corrosion-resistant.  
Through borehole  $\varnothing 25$ .

Clamping power 9000 N.

Connections Laterally, with two lines.

Operation With control unit.

Application On milling and grinding machines and on EDM/WEDM centers.  
To accommodate pallets PM85 Precise and Multi.

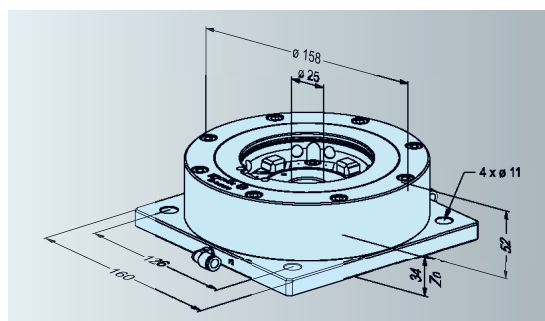

**ER-047500 Chuck PM60 Precise with base plate**



Version Steel, hardened, corrosion-resistant.  
Through borehole  $\varnothing 25$ .

Clamping power 6500 N.

Connections Laterally, with two lines.

Operation With control unit.

Application On milling and grinding machines and on EDM/WEDM centers.  
To accommodate pallets PM60 Precise.

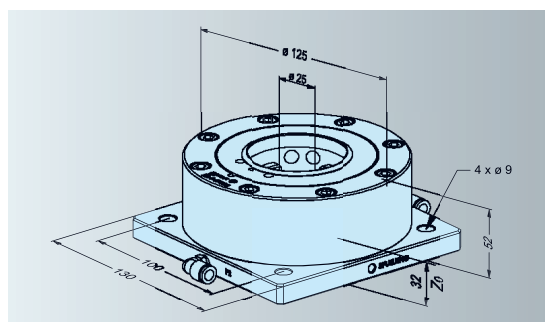

# EROWA PM Tooling Precise Pallets

## ER-034680 Die-plate pallet PM128 $\varnothing$ 52 Precise 1 piece



- Version** Steel, hardened, corrosion-resistant.  
Centering integrated in pallet. Inside  $\varnothing$  52.
- Application** For use on die-plate chuck PM128 Precise. To accommodate die plates, workpieces and fixtures for chip-cutting machines, EDM/WEDM centers and powder presses.
- Fitting blanks** Through the pallet with M6 bolts or through the work-piece with M8 bolts.

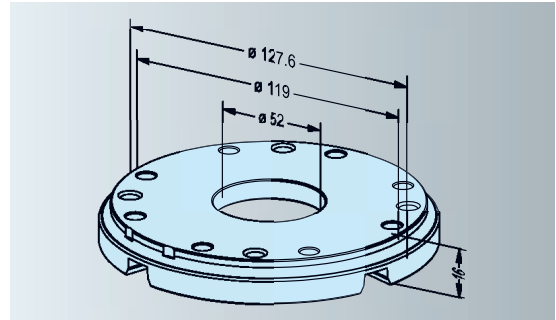

## ER-046927 Die-plate pallet PM128 $\varnothing$ 84.5 Precise 1 piece



- Version** Steel, hardened, corrosion-resistant.  
Centering integrated in pallet. Inside  $\varnothing$  84.5.
- Application** For use on die-plate chuck PM128 Precise. To accommodate die plates, workpieces and fixtures for chip-cutting machines, EDM/WEDM centers and powder presses.
- Fitting blanks** Through the pallet with M6 bolts or through the work-piece with M8 bolts.

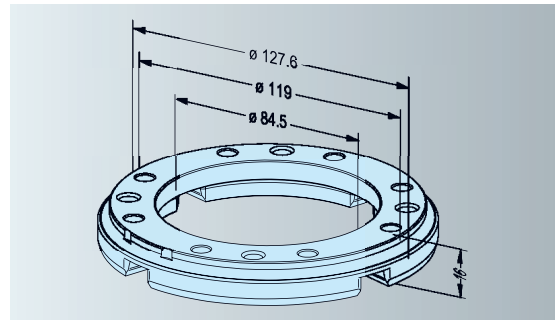

## ER-040701 Pallet PM85 Precise 1 piece



- Version** Steel, hardened, corrosion-resistant.  
Centering integrated in pallet. Inside  $\varnothing$  25.
- Application** For use on Chuck PM85 Precise. With chucking spigot ER-039839 on ProductionChuck 210 Combi, PowerChuck P, ITS Chuck 100 P and QuickChuck 100 P. To accommodate workpieces and fixtures for chip-cutting machines, EDM/WEDM centers and powder presses.
- Fitting blanks** Through the pallet with M6 bolts or through the work-piece with M8 bolts.

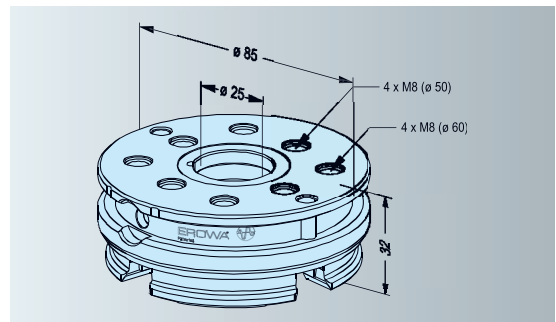

## ER-055369 Pallet PM60 Precise 8 pieces



- Version** Steel, hardened, corrosion-resistant.  
Centering integrated in pallet. Inside  $\varnothing$  25.
- Application** For use on Chuck PM60 Precise. With chucking spigot ER-041429 on ProductionChuck 210 Combi, PowerChuck P, ITS Chuck 100 P and QuickChuck 100 P. To accommodate workpieces and fixtures for chip-cutting machines, EDM/WEDM centers and powder presses.
- Fitting blanks** Through the pallet with M6 bolts.

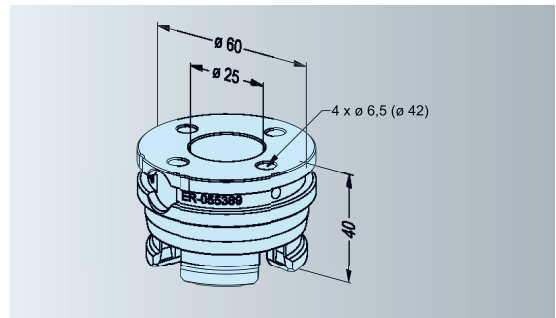

# EROWA PM Tooling Accessories

**ER-035792 Adapter pallet H24 PM Precise for die-plate pallet PM128**



Version Hardened steel, corrosion-resistant.  
Height of pallet: 24 mm.

Application Serves as an adapter between the die-plate pallets PM128 Precise and Multi and an ITS Chuck 100 P or a Power-Chuck P.

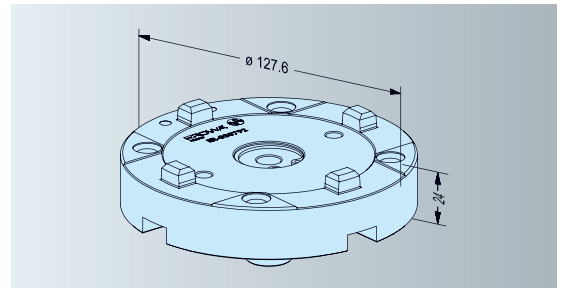

**ER-039839 Chucking spigot PM85 automatic 8 pieces**

**ER-046075 Chucking spigot PM85 automatic 1 piece**



Version Steel, hardened. Automatic, with borehole  $\varnothing$  10.5.

Application In pallets PM85 Precise. To be fitted with securing ring.

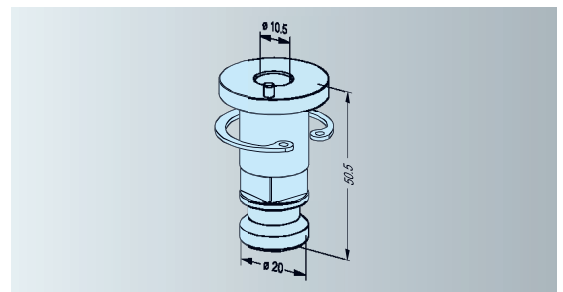

**ER-041429 Chucking spigot PM56 / PM60 manual 8 pieces**

**ER-045759 Chucking spigot PM56 / PM60 manual 1 piece**



Version Steel, hardened. Manual, with borehole  $\varnothing$  10.5.

Application In pallets PM56 and PM60 Precise. To be fitted with securing ring.

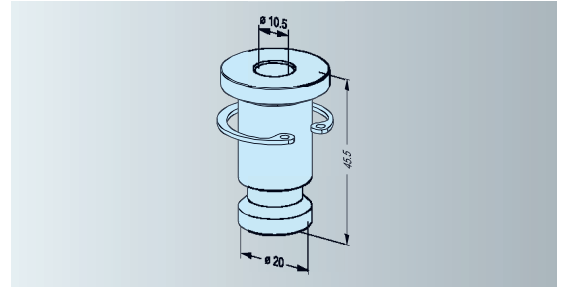

**ER-049248 Alignment pallet PM128 Precise for die-plate chuck PM128 Precise**



Version Steel hardened, corrosion-resistant. Ground alignment surface and centering borehole  $\varnothing$  10.

Application In tool- and mold-making. For alignment of the angle position and determination of the center of the die-plate chuck PM128 Precise.

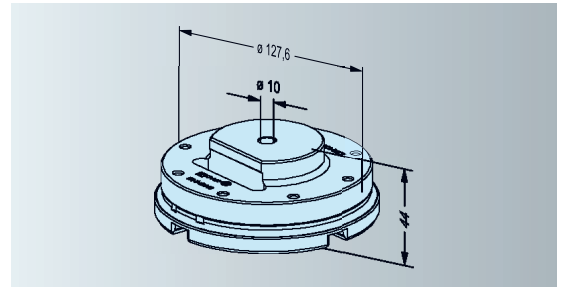

**ER-042440 Alignment pallet PM85 Precise**



Version Steel hardened, corrosion-resistant. Ground alignment surface, center borehole  $\varnothing$  15 and position borehole  $\varnothing$  10.

Application In tool- and mold-making. Alignment of the angle position and determination of the center of PM85 Precise chucks.

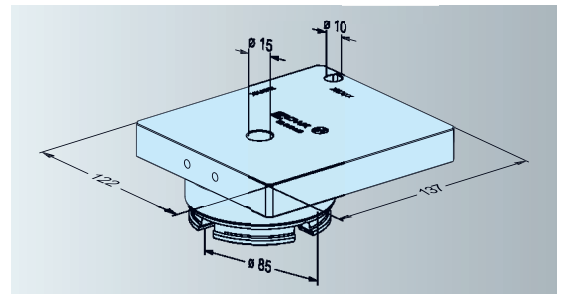

# EROWA PM Tooling Accessories

## ER-042350 Alignment pallet PM56 / PM60 Precise

INOX



Version Steel hardened, corrosion-resistant. Ground alignment surface, center borehole  $\varnothing 9$  and position borehole  $\varnothing 10$ .

Application In tool- and mold-making. To align the angular position and to determine the center of PM56 and PM60 Precise chucks.

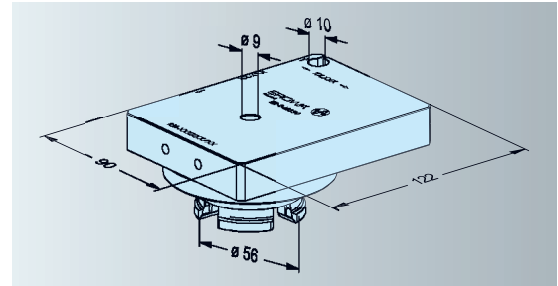

## ER-043427 Alignment pin PM85 Precise

INOX auto



Version Steel hardened, corrosion-resistant. Ground alignment surface and  $\varnothing 45$ .

Application Alignment of the radial and axial positions of PM85 Precise chucks.

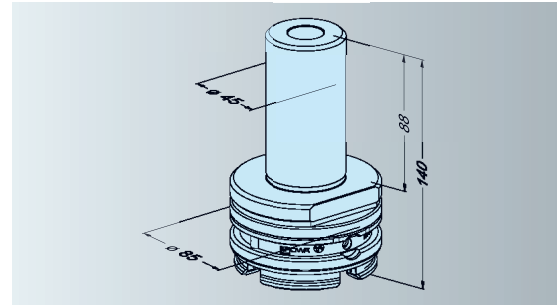

## ER-043428 Alignment pin PM56 / PM60 Precise

INOX auto



Version Steel hardened, corrosion-resistant. Ground alignment surface and  $\varnothing 45$ .

Application Alignment of the radial and axial positions of PM56 and PM60 Precise chucks.

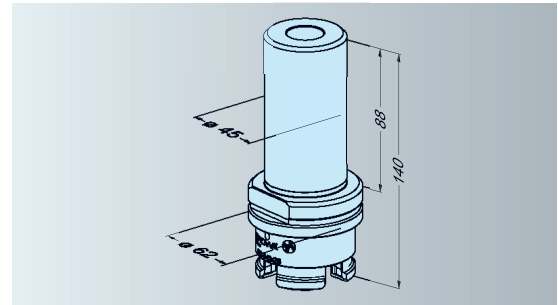

Please note: you can find the entire range in the EROWA PM Tooling System Catalog.



## EROWA spindle adaptation The universal interface

### Minimize resetting time - increase productivity!

With the help of EROWA's spindle-adaptation solution, productive time - for instance in circular grinding - can be substantially increased.

The changeover from a three-jaw chuck to a pneumatically operated tooling system and to customized jigs only takes a few seconds - whilst the highest degree of precision is retained. The basis for all adaptations is the EROWA PM chuck. It is integrated with the machine spindle with the help of a suitable flange. The overall solution is impressive, not least owing to its robust and compact design.



More information.

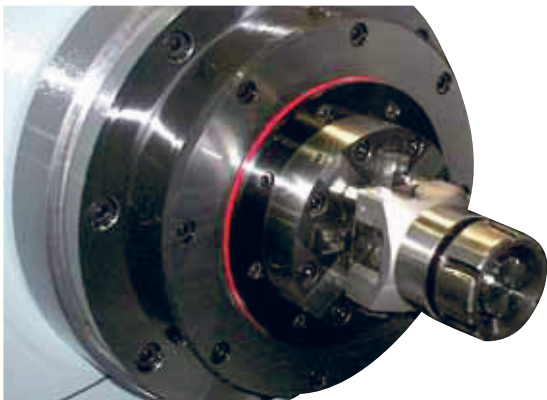
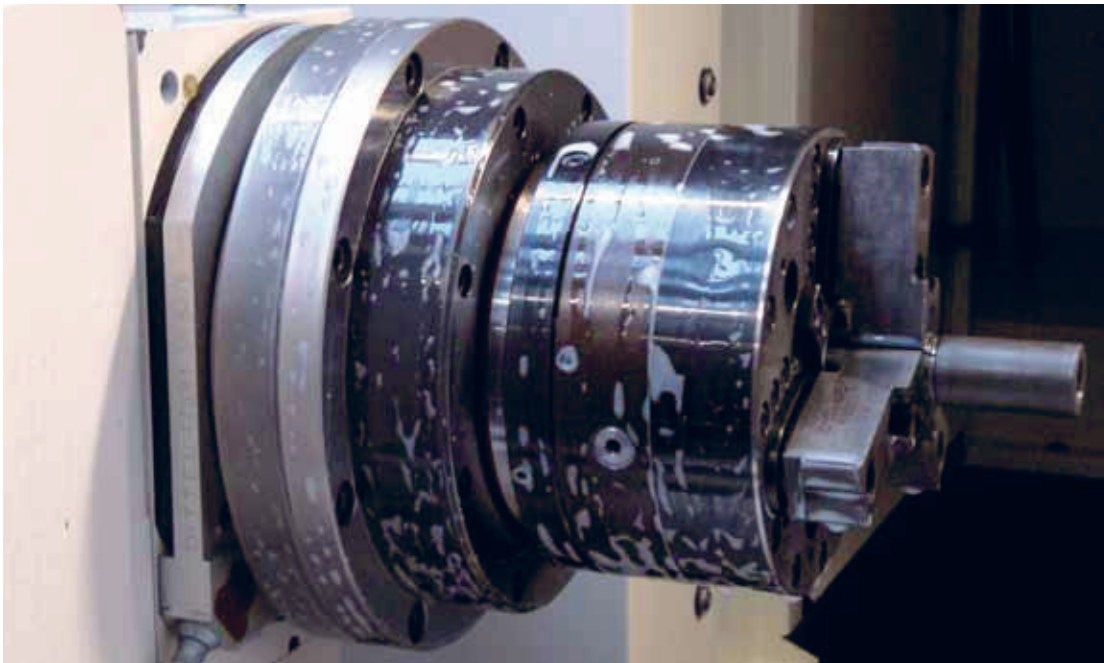

Crucial advantages of EROWA's spindle adaptation:

- Substantially shorter resetting times.
- Minimum height.
- Highest stability and repeatability.
- Maximum concentric accuracy.
- Pneumatic control of adaptations.
- Fully sealed.
- Capable of being automated.

**Applications**



**Handling**

Manual

**Sample application**



The chuck integrated with the machine spindle is opened with compressed air, either through an air-gun or through a fixed air supply.



The three-jaw chuck is inserted. Both run-out and concentricity are repeated to an accuracy of 0.002 mm.



The system is ready for operation in next to no time. Resetting is no longer an essential time factor.



The base chuck is opened and the three-jaw chuck is removed.



The palletized EROWA ITS chuck is inserted. The contour of the pallet completely seals off the spindle.

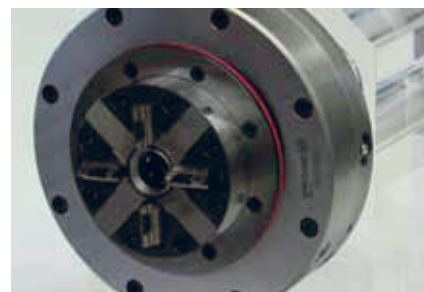

Ready for clamping and positioning to an accuracy of 0.002 mm.

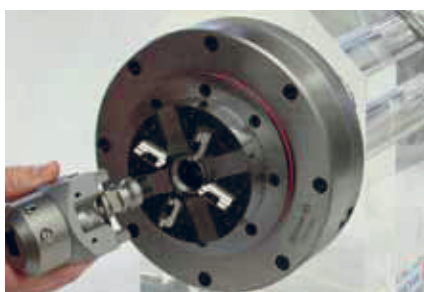

The ITS chuck is opened through the integrated air coupling.



Any EROWA ITS system carrier can be clamped safely, quickly and precisely.



The ITS square holder, for example, serves as a fast-exchange facility for small work-pieces or electrode blanks.

# EROWA spindle adaptation Chucks

Technical data	PM chuck
Repeatability	0,002 mm
Indexation	4 x 90°
Opening with dry compressed air	min. 6 bar
Clamping	Spring pressure

## ER-073369 Die-plate Chuck PM128 II AirDock



Version	Hardened steel. Through hole: $\varnothing 48$ . Outside seal. Positioning ring, including 2 AirDock valves. Max. speed 4000 min <sup>-1</sup> .
Clamping power	23,000 N (reclamped at 6 bar).
Connections	At the rear through customized base plate, flange or rotatable pneumatic connector (not supplied with this unit).
Operation	With compressed-air gun, control unit or through the machine control unit.
Application	On dividing heads, indexing tables, lathes and circular grinding machines. To accommodate adapter chuck, die-plates PM128 and customer-specific jigs.

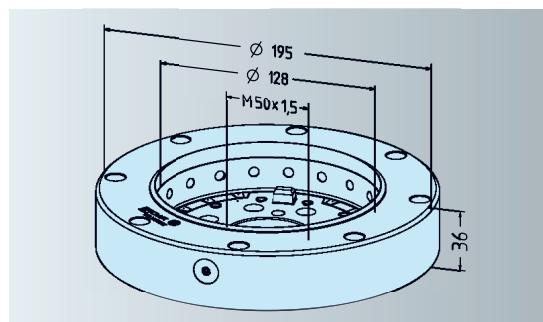

## ER-078473 ITS Chuck 100 P on die-plate pallet PM128 Precise



Version	Hardened steel.
Clamping power	ITS Chuck 100 P: 6,000 N.
Connections	At the rear, to die-plate PM128.
Operation	Through AirDock valves. With compressed-air gun, control unit or through the machine control unit.
Application	As adapter chuck in the die-plate chuck PM 128 II AirDock. To accommodate electrode holders, pallets $\varnothing 115$ , $\varnothing 148$ , PM56, PM60 and PM85 Precise.

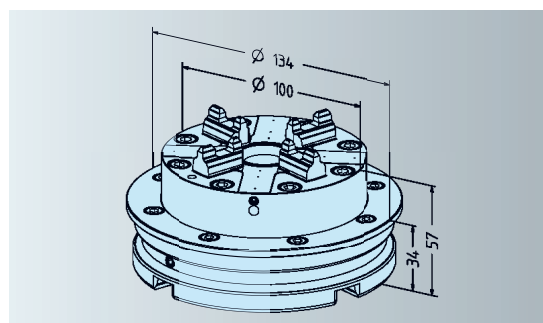

## ER-078474 Manual 3-jaw concentric chuck $\varnothing 125$ mm on die-plate pallet PM128 Precise



Version	Manual 3-jaw concentric chuck $\varnothing 125$ mm. Central clamping area 3-53mm. Body made of cast metal. High degree of concentricity according to DIN 6386. Includes 3 hardened drilling jaws (stepped on the outside), 3 hardened turning jaws (stepped on the inside), 1 spanner.
Note	Max. speed 4000 min <sup>-1</sup> .
Application	As adapter chuck in the die-plate chuck PM128 II AirDock.

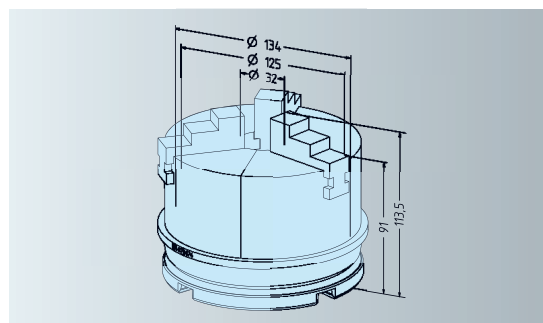

# EROWA spindle adaptation Pallets

## ER-034680 Die-plate pallet PM128 $\varnothing$ 52 Precise 1 piece



- Version** Steel, hardened, corrosion-resistant.  
Centering integrated in pallet. Inside  $\varnothing$  52.
- Application** For use on die-plate chuck PM128 Precise. To accommodate die plates, workpieces and fixtures for chip-cutting machines, EDM/WEDM centers and powder presses.
- Fitting blanks** Through the pallet with M6 bolts or through the work-piece with M8 bolts.

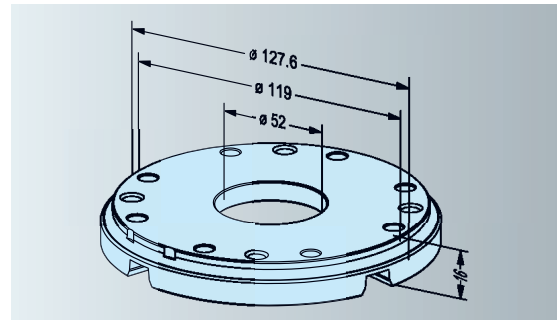

## ER-046927 Die-plate pallet PM128 $\varnothing$ 84.5 Precise 1 piece



- Version** Steel, hardened, corrosion-resistant.  
Centering integrated in pallet. Inside  $\varnothing$  84.5.
- Application** For use on die-plate chuck PM128 Precise. To accommodate die plates, workpieces and fixtures for chip-cutting machines, EDM/WEDM centers and powder presses.
- Fitting blanks** Through the pallet with M6 bolts or through the work-piece with M8 bolts.

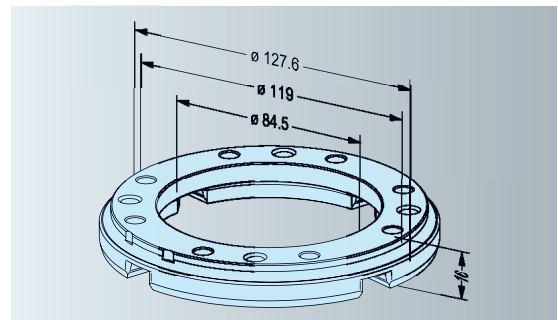

## ER-071890 Alignment pallet PM128 Precise for die-plate chuck PM128 AirDock



- Version** Hardened steel, corrosion-resistant. With ground alignment surface and  $\varnothing$  122. Including M50x1.5 threaded insert.
- Application** In tool- and mold-making. To align angle position and determine the center of die-plate chucks PM128 AirDock.

